

سکاي ستيل سيستمز ذ.م.م
SKY STEEL SYSTEMS

The Chairman's Brief

As Chairman of Sky Steel Systems LLC, I am honored to report the organization's success based on recent achievements and participation in the region's largest projects. We have been provided with remarkable opportunities for expansion thanks to our constant global growth, and technological changes at various business sectors and industries. Sky Steel Systems' proficient management team has introduced invaluable and innovative ideas to the business and its services. Added to the regular research of the market and technological development, our team strives to use their individual commercial and technical expertise.

Effectively, the company has been consistently proving, particularly at this challenging period of change, that it is at the leading edge of the business spectrum. With far-vision targets and a portfolio that aims to keep the pace with customer demands, Sky Steel Systems is escalating the market as it concentrates efforts on up-to-date technology and bigger capacity access systems.

Therefore, it is essential that the entrepreneurship, flexibility and youthful approach remain amongst our management team. It is also of equal importance that professionalism and personal consideration is always taken into account, during and post service. Our organization will prevail in achieving the Sky Steel Systems' mission in terms of technology, quality, market awareness and industrial proficiency; both on a local and international level.

To achieve this, I have committed myself to setting simple yet strategic goals, designed for the competent management team that we have employed. This includes a mutually beneficial business development plan along with retention of qualified staff; resulting in unparalleled operational success. I am looking forward with optimism and enthusiasm to the challenges that lie ahead, as I have every faith in our strategy for expansion and our ability to meet our clients' demands, trust and expectations.

I am particularly grateful for the opportunities provided by this rapidly developing city; Dubai has been cooperative and inviting to businesses of all industries. Without its continuous support, our success could not have been achieved. We have also been fortunate enough to be granted part of this prosperous land. We are currently expanding our business offices and manufacturing facilities at one of the leading Industrial zones; Dubai Investments Park. With specific address to our local and international business associates and partners, I assure them my full cooperation and dedication of all my staff at Sky Steel Systems.

Abdulaziz B. Binladin
Chairman

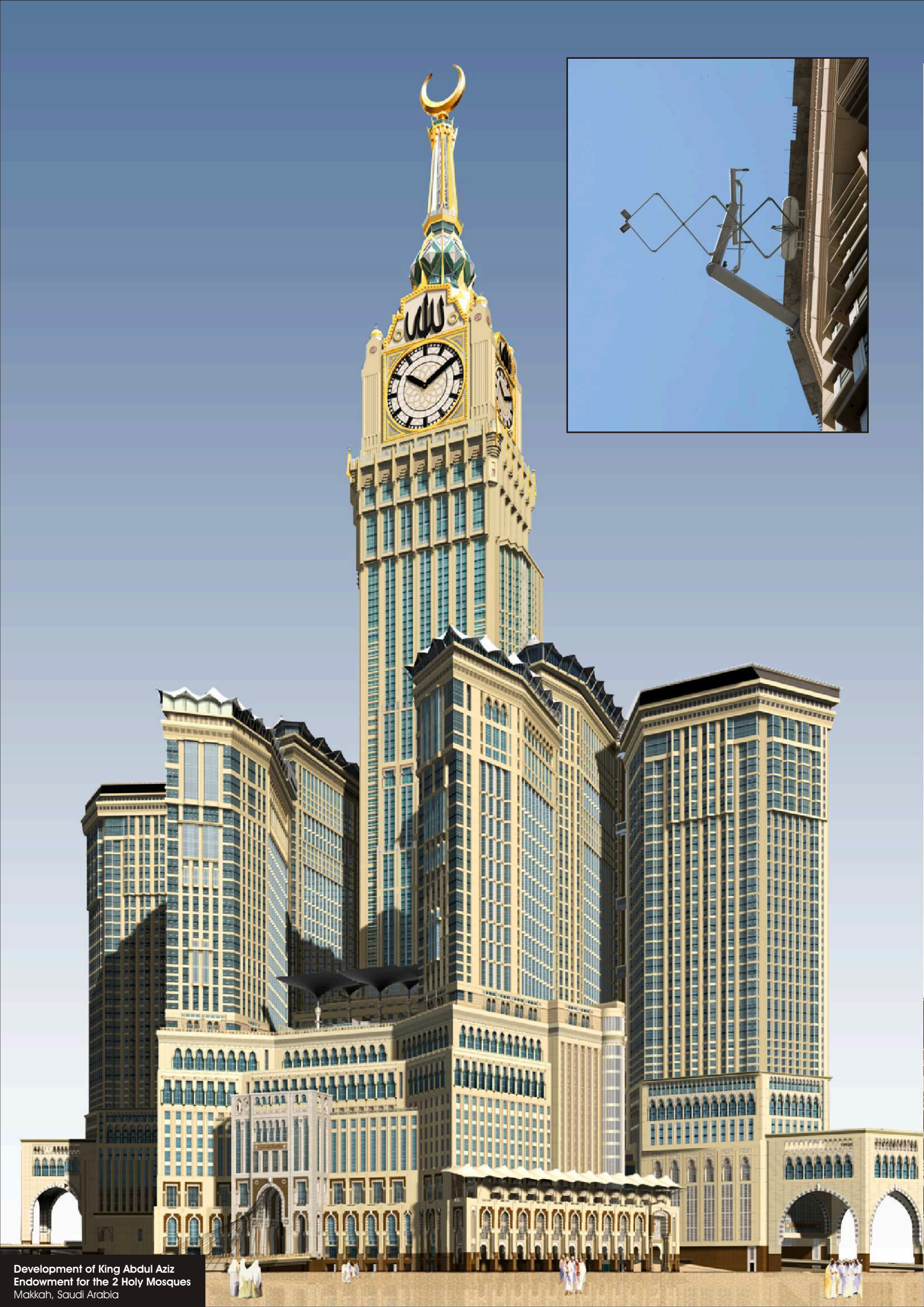

Our Mission

“The Sky is just the beginning”

Sky Steel Systems is an absolute turnkey access solution provider for high and low-rise structures.

Our aim is to become a worldwide leader in access equipment.

We plan to achieve this by ensuring the following:

- Better solutions for our customers; including prompt service and excellence in quality and efficiency.
- Provision of cost-effective Access Equipment Solutions.
- Distinguished Project Management and supervision
- An Immaculate Safety Record.
- Full Compliance with European Safety Standards.
- Reliable execution of services
- Full Commitment and technical support.

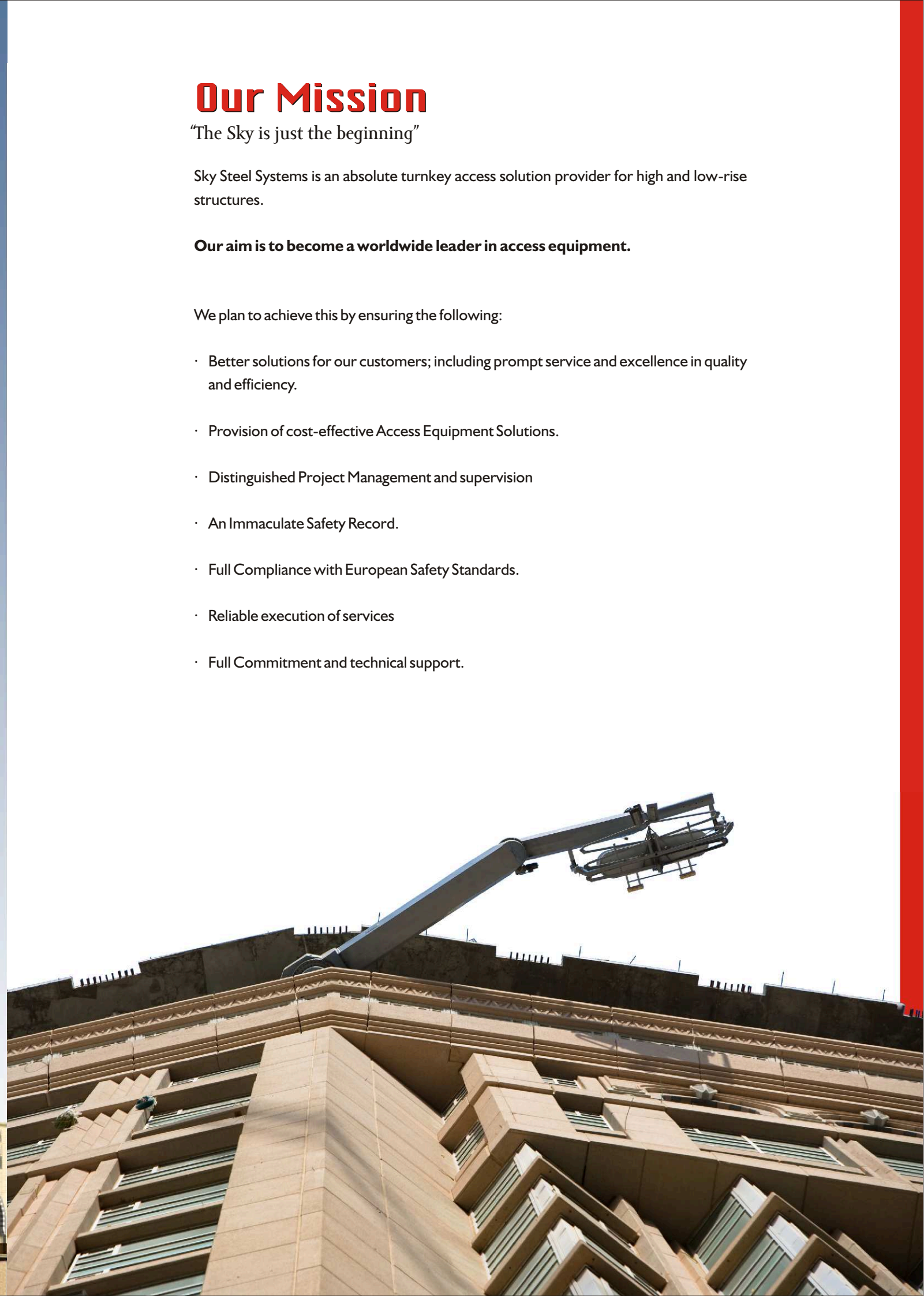



Core Values

'Our Absolute Fundamentals'

- Adhere to quality and Integrity at all times.
- Regulate our business and ourselves: lawfully, ethically and morally.
- Conduct business at maximum safety and accuracy, from the point of commencement.
- Client priorities predominate.
- Become the benchmark of our industry and 'be the best'.
- Approach our workforce as our most vital resource.
- Sustain regular expansion and growth in all relevant fields.

Our Ambition

"Our Aspiration"

Sky Steel Systems becomes the Region's premier access systems manufacturer and installer.

"When a client turns to us for services, we do not simply meet their expectations- we exceed them".





Company Overview

Sky Steel Systems LLC (SSS) is an engineering company located in Al Awir Industrial Zone of Dubai. It primarily specializes in the design, manufacture and installation of a diversified range of access systems created for the purpose of both, external and internal cleaning and maintenance of buildings.

Our facilities include a machine workshop, steel structural fabrication, stainless steel works, material handling equipment and a fabrication section. We employ an exceptional team of qualified and experienced foremen, supervisors, mechanical technicians, fabricators, welders, machinists and electricians along with a team of skilled workforce.

Our access systems are accurately designed and custom-made to suit the design requirements of each building. The equipment solutions at Sky Steel Systems are set to reach the highest quality standards of worldwide access systems.

Moreover, to guarantee the accomplishment of our objectives, authority certification in the industry's standard quality control has been obtained. International consultants are sought for inspections and verifications to ensure S.S.S. products meet the maximum levels of safety and operational standards.

To secure the above standards, product development is a fundamental process of the organization, and a group of qualified and certified engineers are involved for this acute purpose.

In response to specific requirements of demanding or complex projects, Sky Steel Systems has a preferential affiliation with FARRA (www.farra.co.nz), an industry leader across the pacific continent in access equipments and solutions. FARRA is an integrated engineering company, which has been manufacturing internal and external suspended access to high and low-rise buildings for the last 140 years. Their services include the designing, manufacturing and installing of safe and durable engineering solutions.

S.S.S. Management Team possesses a significant magnitude of experience and colossal knowledge, in addition to prime qualifications in the field of building access systems. Furthermore, Dubai has directed us to astounding progress along with its rapid growth. Our future office headquarters, which are currently under the process of construction in Dubai Investments Park, will include full-fledged facilities; it is our mission and ambition to become a worldwide leader in Access Solutions.

The company's capacity has been increasing invariably, strengthening the confidence in executing larger scale projects and enabling us to invest in new products, innovations and methods of production, Sky Steel Systems is steadily expanding and is developing into a major regional leader. Its choice of working with such a competent team stems from the successful approach it follows; "Effective project management, dedicated supervision and an intact safety record will keep us at the peak of our industry".



Performance Culture

'Witness our Operational Environment'

Our Services

Engineering:

Our Engineering team consists of certified, experienced engineers, who have conducted over 500 successful projects throughout the region. Thus it is imperative to acknowledge the team's professional work, which we recognize through the results of our solutions. The team's efforts have also been portrayed in the comprehensive achievement of client requirements as well as the reliable meeting of client demands.

Sales:

We hold gratitude to our enthusiastic and knowledgeable Sales Team. Thanks to their assertiveness and professional approach, we have been able to provide efficient and outstanding post-sales as well as maintenance services to all our customers.

Maintenance:

An essential and critical service, warranty and non-schedule maintenance is guaranteed with our experienced and certified engineers and technicians, whom are ultimately available at a short notice.

Maintenance Contracts:

Following the end of the contractual maintenance period, annual maintenance contracts are undertaken to further ensure that the systems are functional and well maintained over a long contractual period of time.

Spare Parts Supply:

We ensure the availability of spare parts for our systems and products for a period as long as 10 years. Functional spare parts that are in demand can be found in stock for quick supply and uninterrupted operation.





Organizational Histogram

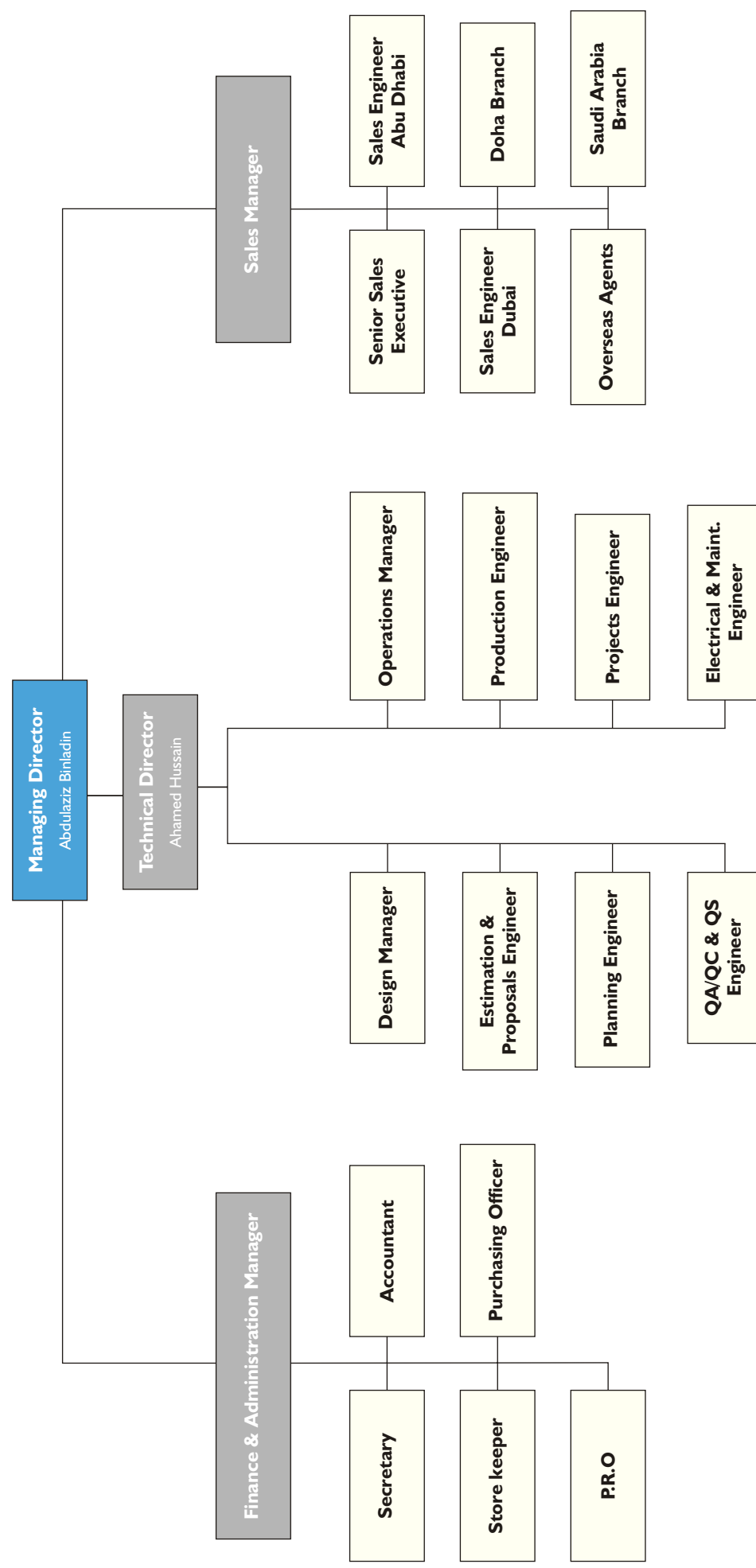

A Selection of our Projects

No.	Project Details	Location	Consultant	Contractor	System
1	Development of King Abdul Aziz Endowment for the 2 Holy Mosques (7 Towers and plaza complex with maximum height 591 m)	Makkah, Saudi Arabia	DAR Al Handasah	Saudi Bin Ladin Group	Multiple Systems Telescoping and Knuckle slewing machines up to 32 m reach Pantograph/Telescopic cradles Special Systems for catering to special requirements
2	Jumeirah Beach Residence - 5 Towers (Complex with maximum height 178m)	Dubai	W. Atkins Consultants	Al Ahmadi Cont.Co.	Telescopic Roof Trolleys with Pantographic cradle Max. reach 18 m
3	New Doha International Airport-CCP 18: Passenger Terminal Complex (Phase I and Phase II)	Doha, Qatar	Overseas Bechtel	Sky Oryx Joint Venture	Special systems
4	Business Bay Dubai Properties - 5 Towers (Maximum Tower height 185Mt.)	Dubai	Design Architecture Bureau (DAR)	Al Habtoor Engineering	Telescopic and knuckle slewing Roof Trolleys with 15m reach
5	Sheraton Heliopolis Extension	Cairo, Egypt	Wimberly Allison Tang & Co.	Consolidated Contractors International Company	Roof Trolley Monorails, Gantries
6	Al Reem Island Phase I Zone C - 5 Towers	Abu Dhabi	GDP Architects International	ISZL (IJM Sunway Zelan LFE)	Roof Trolleys with knuckle jibs
7	4B+G+34+ 1 Tech Tower	JLT, Dubai	Engineer Adnan Saffarini	Tiger Contracting Co.	Monorail System
8	Burj Views - 3 Towers (Maximum tower height 133m)	Burj Dubai development, Dubai	NORR Consultants	Saudi Bin Ladin Contracting	Telescopic Roof Trolley with reach upto 18m
9	Habib Bank	Karachi, Pakistan	Loya Associates Consultant		Roof Trolleys
10	G+2P+ 13 Building	Sharjah	Ajiyad Engineering Consultants	Tiger Contracting Co.	Roof Trolley
11	Dubai Oasis	Dubai	Adnan Saffarini, Consultants	Saudi Bin Ladin Contracting	Monorail Systems
12	Residence Bldg. at Mamzar in Sharjah P84	Sharjah	Khatib & Alami Consultants	Tiger Contracting Co.	Monorail System
13	Damas Towers (Twin tower complex with maximum tower height 220m)	Dubai	Engineer Adnan Saffarini	Bin Zayed Construction	Telescopic special Roof Trolleys with lifting knuckle jibs
14	B+G+24 Floor	Dubai	Shadid Engineering	Al Habtoor Engineering	Monorail System
15	Al Sari towers (Maximum Tower height 185m)	Dubai	Arenco	Al Nekhreh Contracting	Roof Trolley



Development of King Abdul Aziz Endowment for the 2 Holy Mosques
Makkah, Saudi Arabia



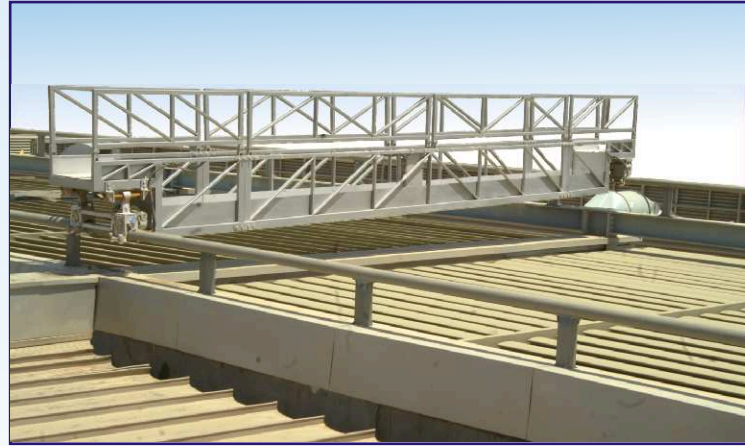

Sheraton Heliopolis Extension
Cairo, Egypt

Jumeirah Beach Residence
Dubai



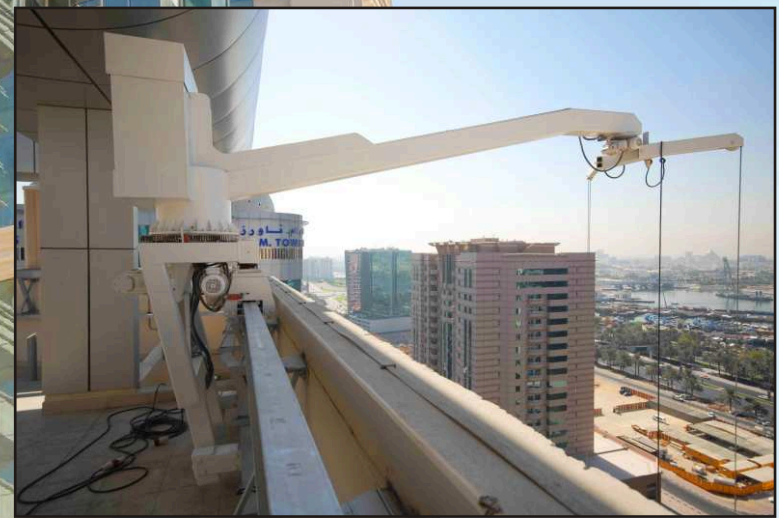
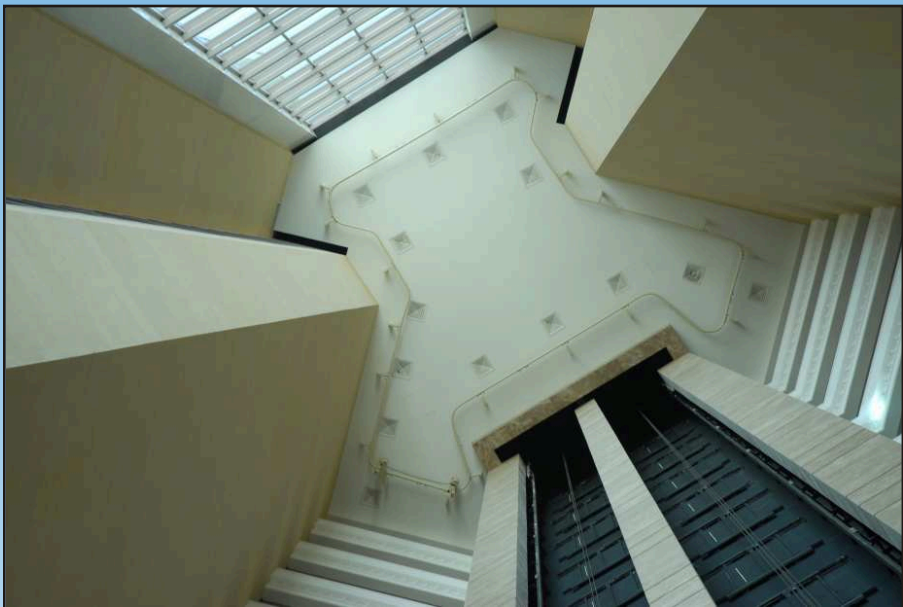

Monorail Systems

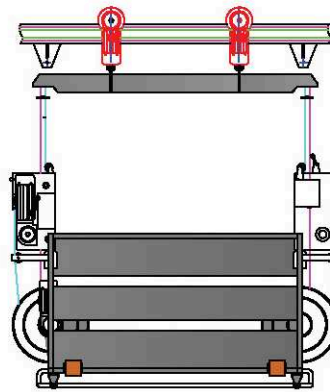
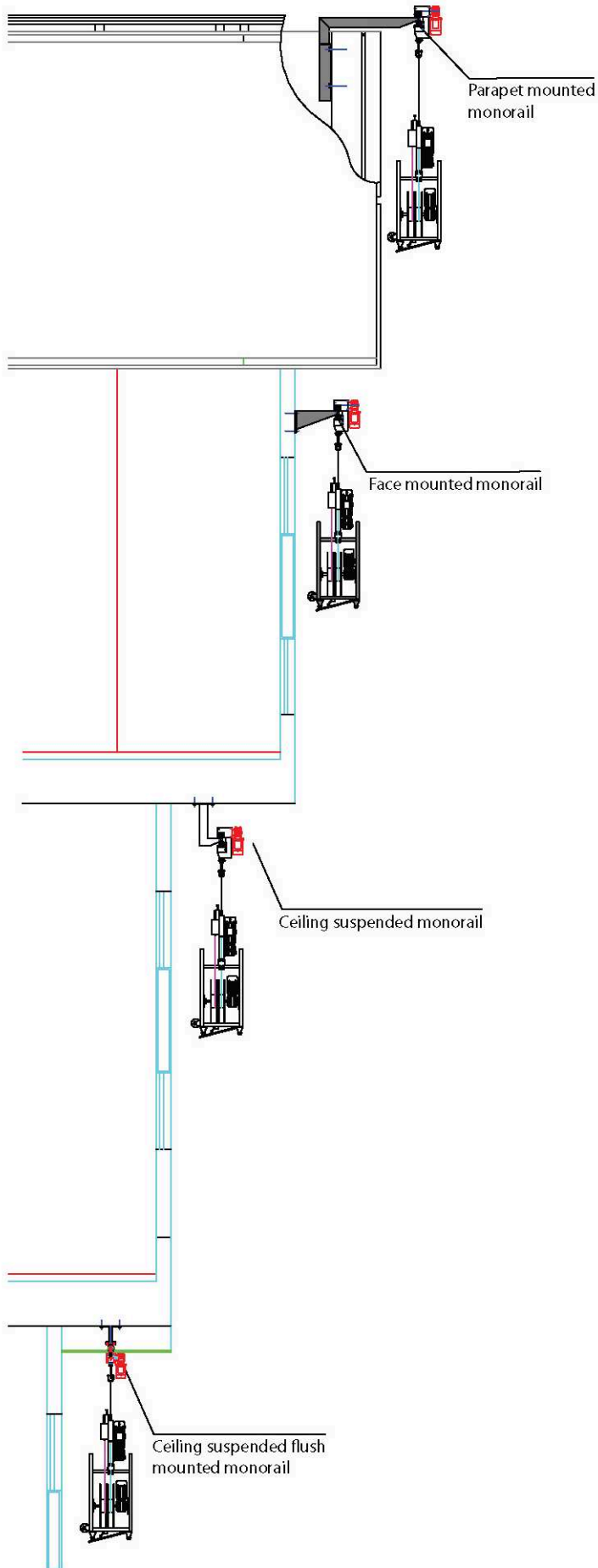

Horizontal monorail system

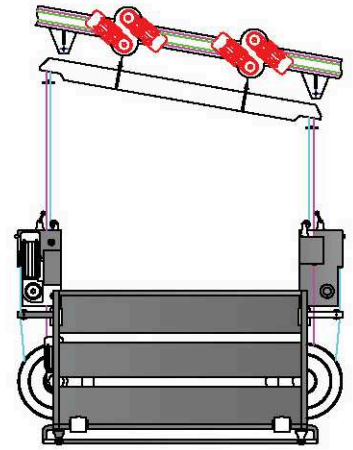

Inclined Climbing monorail system

Exposed monorail trolley

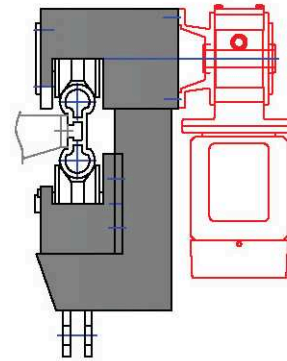

Technical Data

Safe Suspended Load : 6 kn per trolley
 Traversing Speed : 7 m/min.
 Traversing Drive : 0.37 kw
 Power Supply : 400v/3ph/50hz

Flush mounted monorail trolley

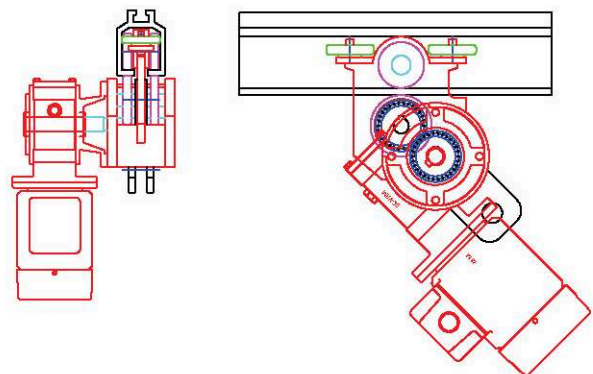

Technical Data

Safe Suspended Load : 6 kn per trolley
 Traversing Speed : 7 m/min
 Traversing Drive : 0.37 kw
 Power Supply : 400v/3ph/50hz

Monorail Systems

Monorail Systems Details & Options

Monorail Track Profile Options

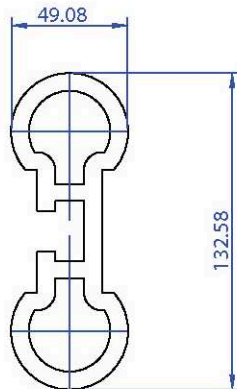

Exposed Monorail

PROFILE SSS-M101

Material: Aluminium Alloy 6061 Temp T6

WEIGHT : 6.64 Kg/M

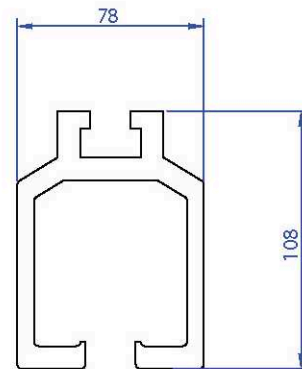

Flush mounted Monorail

PROFILE SSS-M102

Material: Aluminium Alloy 6061 Temp T6

WEIGHT : 7.07 Kg/M

Monorail Track Mounting Options

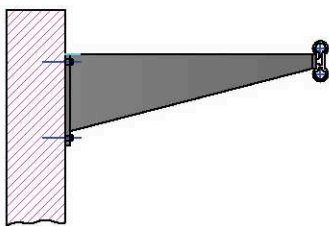

Face mounted Monorail

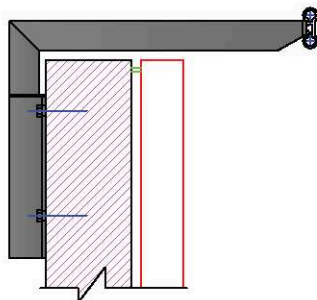

Parapet mounted Monorail

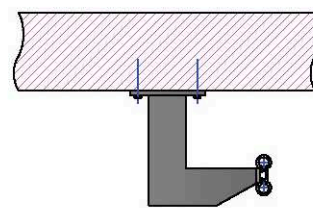

Ceiling Suspended Monorail

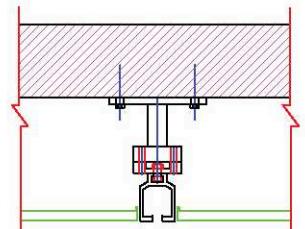

Ceiling Suspended Flush Mounted Monorail

Technical Data

MOTORS		
	One man Cradle 1 to 1.5 M	Two man Cradle 2M or more
Hoisting	0.75Kw x 1 No	0.75Kw x 2 No
Wire Winder	0.37Kw x 1 No	0.37Kw x 2 No
Traversing	0.37Kw x 1 No	0.37Kw x 2 No
Traversing (Climbing Monorail)	0.37Kw x 2 No	0.37Kw x 4 No

Wire Rope Suspension system

wire rope Dia : 8.4 mm
 wire rope construction : 5x26
 Finish : Galvanised
 Breaking Load : 51 KN each

SAFE WORKING LOAD	
One man Cradle 1 to 1.5 M	Two man Cradle 2M or more
120 KG (or as ordered)	240 KG (or as ordered)

NO. OF WIRE ROPES	
One man Cradle	Two man Cradle
2	4

Speeds

Traversing : 6 M / min
 Hoisting : 8 M/min

Monorail Track Data

Material : Aluminium Alloy 6061 Temp T6
 Finish : Mill Finish/ Anodized/ Polyurethane
 Coat/ Powder Coat to Required Ral Code

Safety Features

- Electromagnetic brake
- Slack rope safety device with brake
- Top limit safety switch
- Bottom limit & obstruction sensing safety switch with trip bar
- Traversing end limit - left
- Traversing end limit - right
- ELCB
- No Power emergency manual descent
- Emergency Stop

Power Supply

380/415 V-3Ph-50Hz+Earth&Neutral

Options available with Powered Trolley

with winch on trolley, machine slewing and spreader slewing

Monorail Systems Details & Options

Spreader Options

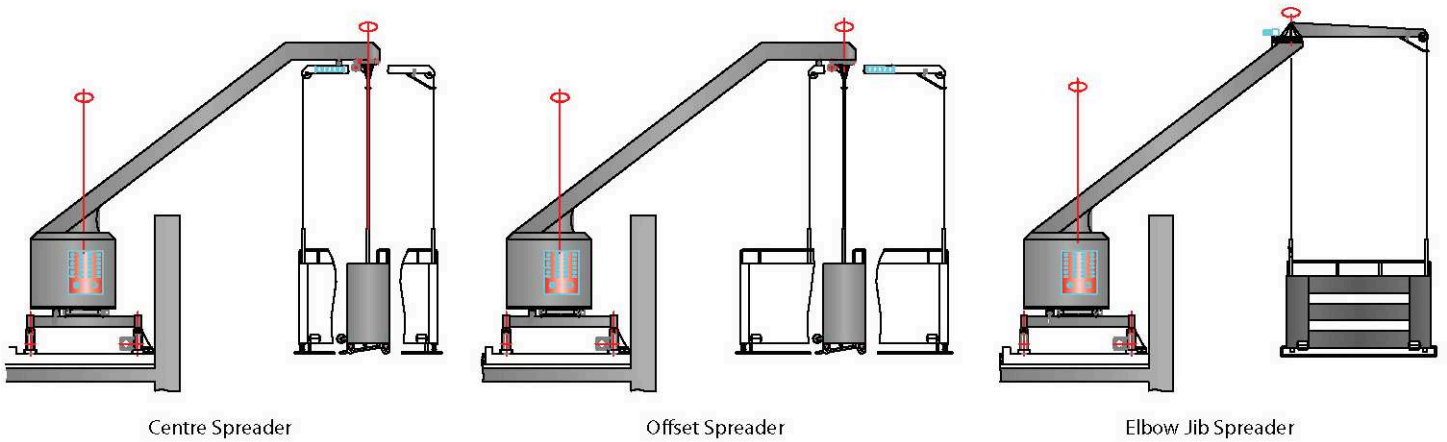

Centre Spreader

Offset Spreader

Elbow Jib Spreader

Track Options

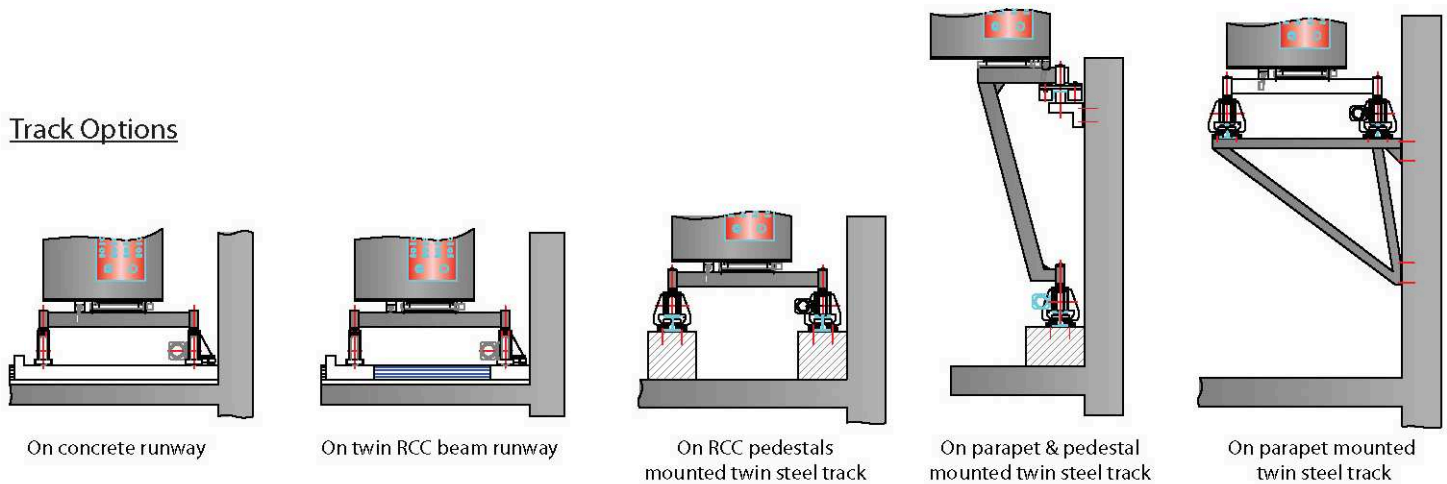

On concrete runway

On twin RCC beam runway

On RCC pedestals mounted twin steel track

On parapet & pedestal mounted twin steel track

On parapet mounted twin steel track

	CANTILEVER X 2000 MM	CANTILEVER X 3000 MM	CANTILEVER X 4000 MM	CANTILEVER X 5000 MM
A - WIDTH OF CONCRETE RUNWAY	2000	2000	2250	2500
B	200	200	225	225
C - WHEEL GAUGE	1550	1550	1750	2000
D	250	250	275	275
MAXIMUM WHEEL LOAD IN 45° SLEWED POSITION IN " KN"	22.0	26.0	28.5	33.5
TOTAL WEIGHT OF THE SYSTEM WITH CRADLE, SWL & IF IN KN	33.5	40.5	44.5	53.5
SAFE WORKING LOAD (SWL) ON THE CRADLE IN KG	240	240	240	240

Note: The data provided is for general information only & subject to change without prior notice for upgradation & application. Technical data for specific application available on request.

Powered Trolley on Concrete Runway

with machine slewing, Spreader Slewig & self powered Double Stirrup cradle

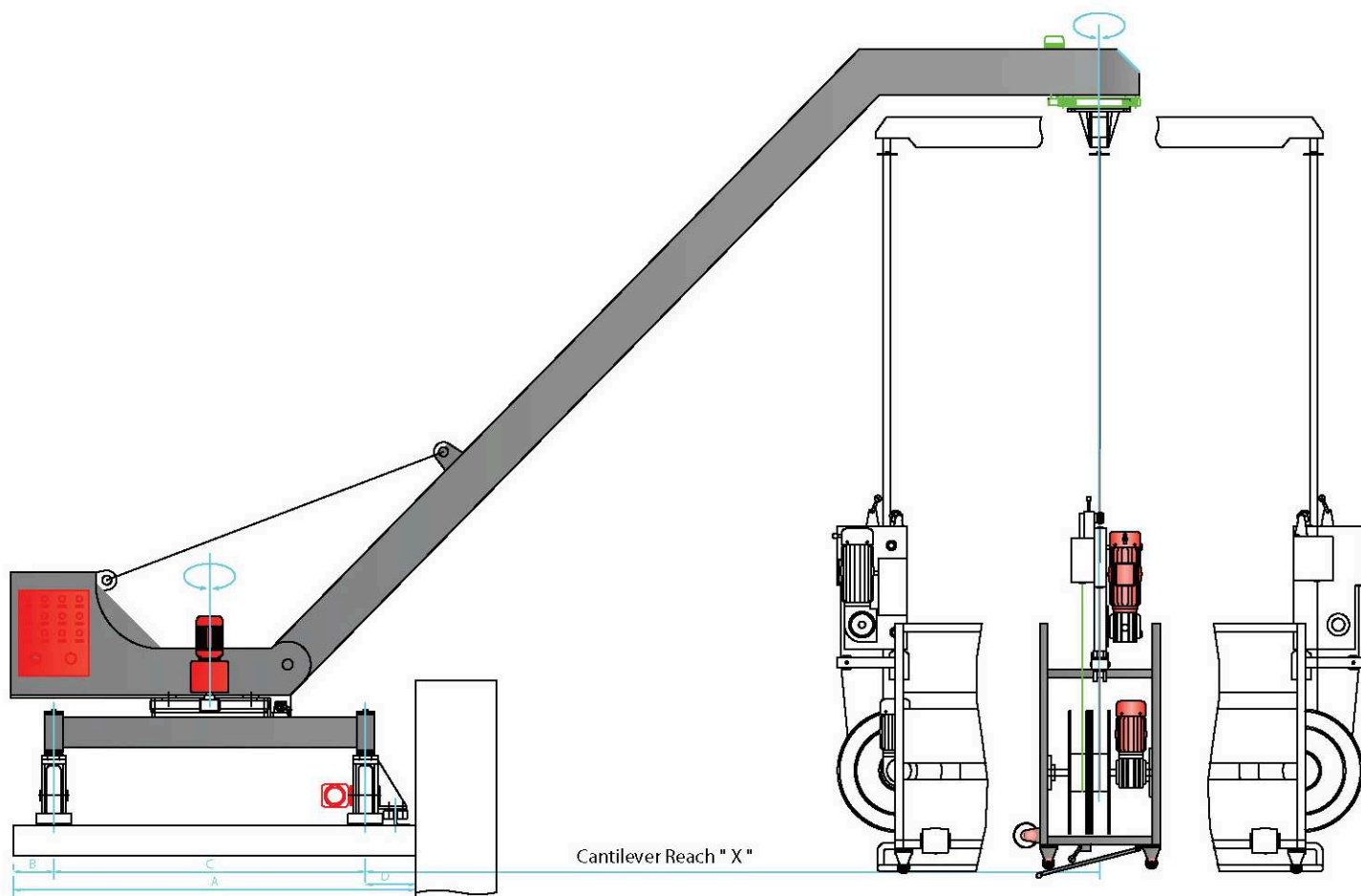

Technical Data

Speeds

Traversing	: 8 M/min
Slewing	: 200° / min
Spreader Slewing	: 1.6 RPM
Hoisting	: 8.5 M/min

Motors

Traversing	: 0.25KW x 2nos
Slewing	: 0.37 KW x 1 no
Spreader Slewing	: 0.25 KW x 1 no
Hoisting	: 0.75 KW x 2 nos
Wire Winder	: 0.37 KW x 2 nos

Four Wire Suspension system

wire rope Dia	: 8.4 mm
wire rope construction:	5x26
No of wire ropes	: 4 nos
Finish	: Galvanised
Breaking Load	: 51 KN each

Control at Cradle

- Cable Control

Finishing & Corrosion Protection

- Abrasive blasting to SA2.5
- 1 coat Zinc Primer
- 2 coats of polyurethane to required RAL colour code

Roof Trolley Track

Track	: RCC Concrete Runway
Trolley Guidance	: Hot dip galvanised steel angular guide rail

Cradle

Basket size	: 2000Lx600Wx1100H
Overall Size	: 2000Lx725Wx1800H
Safe Working Load	: 240 kg
Options	: Special sizes available to suit requirement

Cradle Option

- Self Powered Double Stirrup Cradle
- Walk through Stirrup cradle
- Single Stirrup Cradle
- Self powered Slewing cradle

Safety Features

- Electromagnetic brake
- Slack rope safety device with brake
- Top limit safety switch
- Bottom limit & obstruction sensing safety switch with trip bar
- Traversing Safety limit - left end
- Traversing Safety limit - right end
- Slewing safety limit switch - CW
- Slewing safety limit switch - CCW
- Spreader Slewing safety limit switch- CW
- Spreader Slewing safety limit switch-CCW
- ELCB
- No Power Emergency Manual Descent
- Emergency Stop

Power Supply

380/415 V-3Ph-50Hz+Earth&Neutral

Options available with Powered Trolley with machine slewing and spreader slewing

Spreader Options

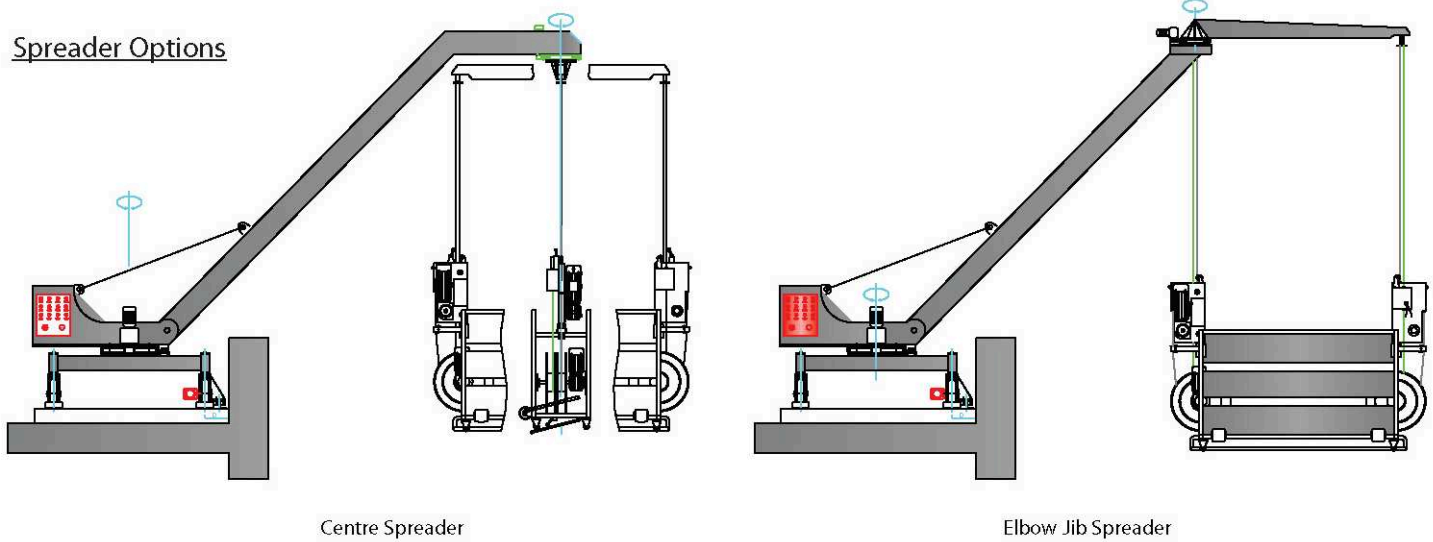

Centre Spreader

Elbow Jib Spreader

Track Options

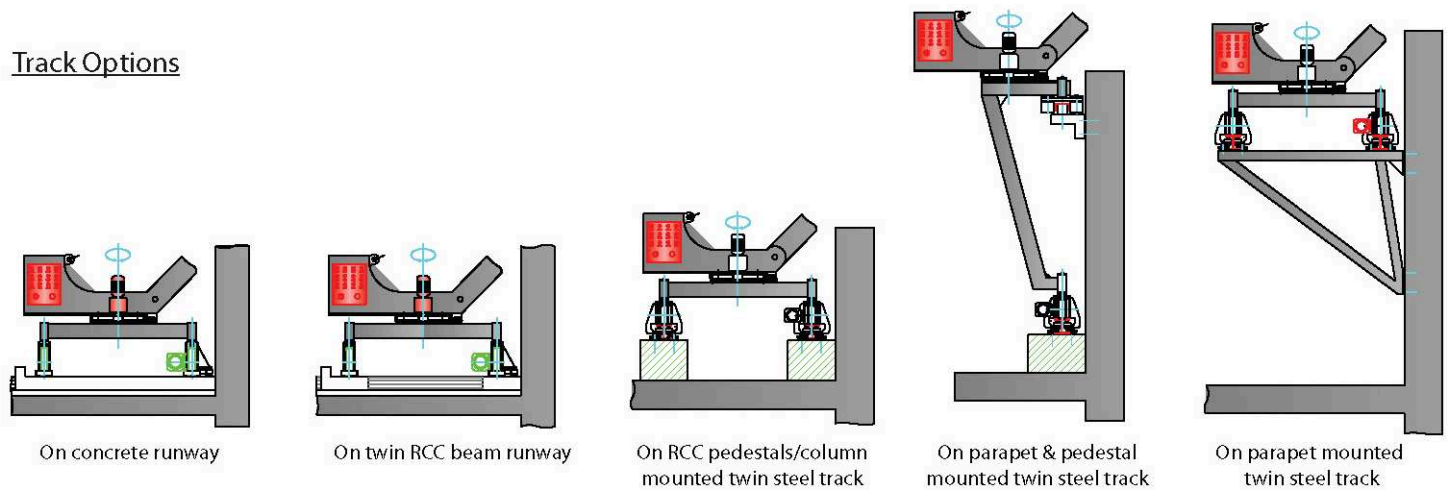

On concrete runway

On twin RCC beam runway

On RCC pedestals/column mounted twin steel track

On parapet & pedestal mounted twin steel track

On parapet mounted twin steel track

	CANTILEVER X 1500 MM	CANTILEVER X 2000 MM	CANTILEVER X 2500 MM	CANTILEVER X 3000 MM
A - WIDTH OF CONCRETE RUNWAY	2000	2000	2250	2250
B	200	200	200	200
C - WHEEL GAUGE	1550	1550	1800	1800
D	250	250	250	250
MAXIMUM WHEEL LOAD 45° SLEWED POSITION IN " KN"	23.0	27.2	28.8	33.4
TOTAL WEIGHT OF THE SYSTEM WITH CRADLE, SWL & IF IN KN	34.7	40.7	44.4	53.3
SAFE WORKING LOAD (SWL) ON THE CRADLE IN KG	240	240	240	240

FURTHER OPTIONS

- Trolleys with manual spreader

Note: The data provided is for general information only & subject to change without prior notice for upgradation & application. Technical data for specific application available on request.

Powered Trolley on Concrete Runway

with winch on trolley, machine slewing, luffing & standard cradle

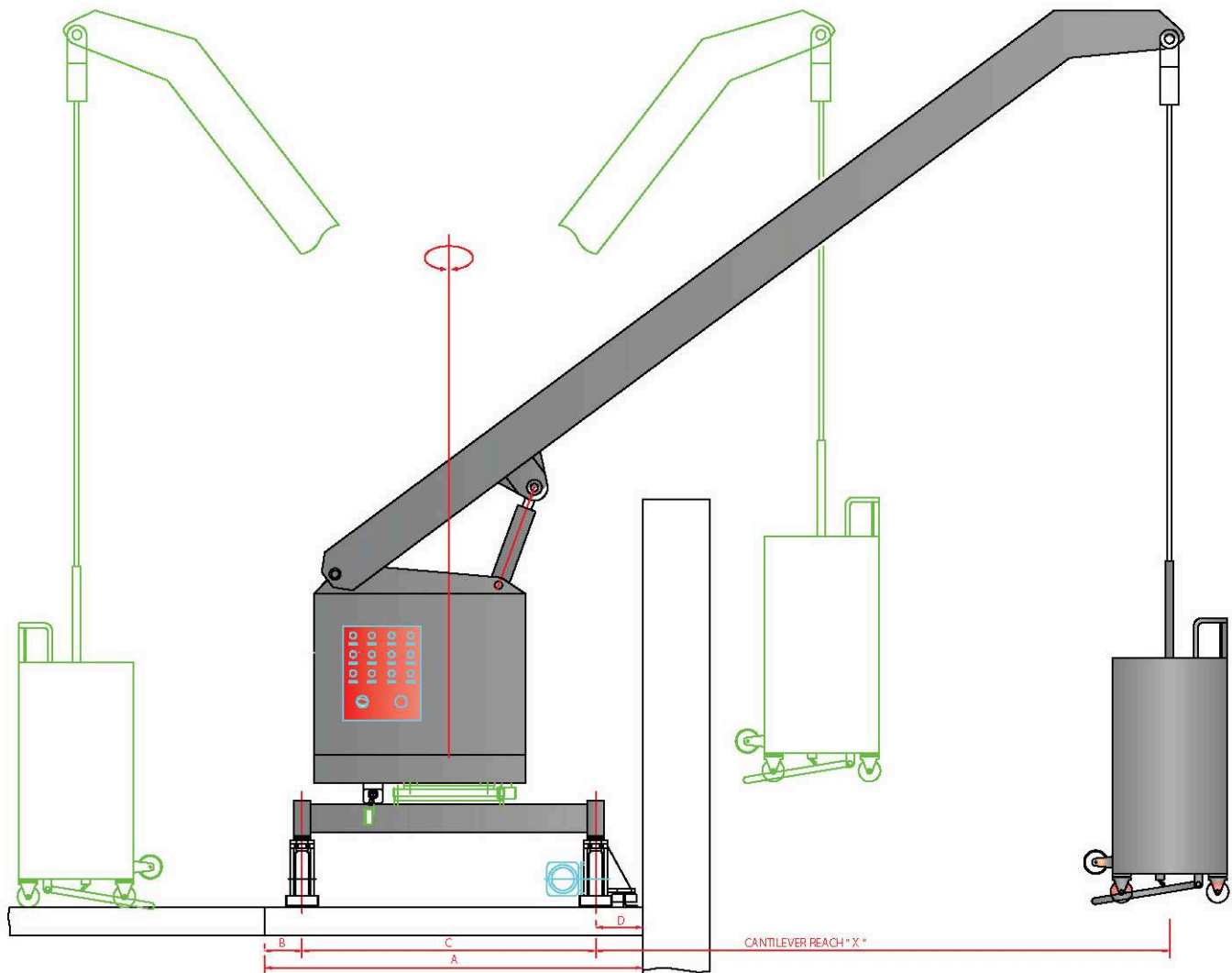

Technical Data

Speeds		Finishing & Corrosion Protection		Safety Features	
Traversing	: 8 M/min	- Abrasive blasting to SA2.5		- Electromagnetic brake	
Slewing	: 8 M/min tip speed	- 1 coat Zinc Primer		- Overspeed Block Stop with brake	
Luffing	: 45°/min	- 2 coats of polyurethane to required		- Overload integrated with winch	
Hoisting	: 8 to 10 M/min	RAL colour code		- Top limit safety switch	
Motors		Roof Trolley Track		- Bottom limit & obstruction sensing safety switch with trip bar	
Traversing	: 0.37KW x 2nos	Track	: RCC Concrete Runway	- Traversing Safety limit - left end	
Slewing	: 0.37 KW x 1 no	Trolley Guidance	: Hot dip galvanised steel angular guide rail	- Traversing Safety limit - right end	
Luffing	: 0.55 KW x 1 no	Cradle		- Slewing safety limit switch - CW	
Hoisting	: 1.5 KW x 1 no	Basket size	: 2000Lx600Wx1100H	- Slewing safety limit switch - CCW	
Four Wire Suspension system		Overall Size	: 2000Lx725Wx1800H	- Luffing safety switch-Top Limit	
wire rope Dia	: 6 mm (standard)	Safe Working Load	: 240 kg	- Luffing safety switch-Bottom Limit	
wire rope construction	: 5x26	Options	: Special sizes available to suit requirement	- ELCB	
No of wire ropes	: 4 nos	Cradle Option		- No Power Emergency Manual Descent	
Finish	: Galvanised	Standard Cradle		- Emergency Stop	
Breaking Load	: 21 KN each	Cantilever Cradle		Further Options	
Wire rope options	: 8 mm dia	Slewing Cradle		- Trolley with spreader slewing	
	: Conductor wire ropes	Panthograph Cradle		Power Supply	
Control Options		Telescopic Cradle		380/415 V-3Ph-50Hz+Earth&Neutral	
- Cable Control					
- Control through conductor wire ropes					
- Radio Remote Control					

Options available with Powered Trolley

with winch on trolley, machine slewing and Luffing

Track Options

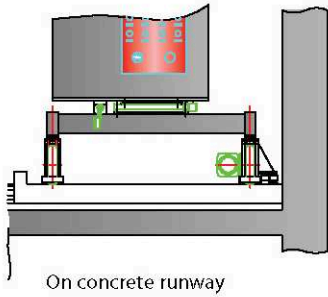

On concrete runway

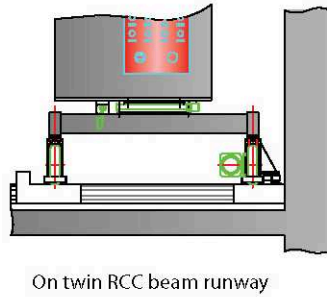

On twin RCC beam runway

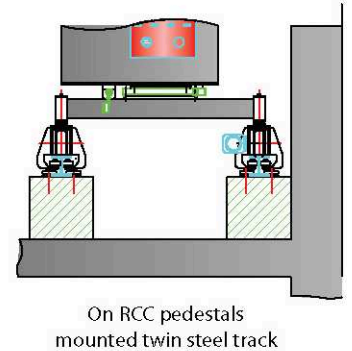

On RCC pedestals mounted twin steel track

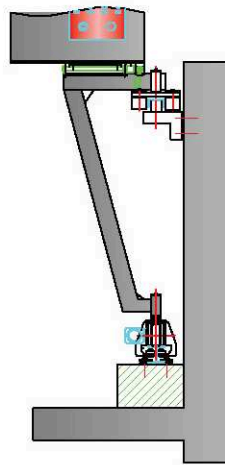

On parapet & pedestal mounted twin steel track

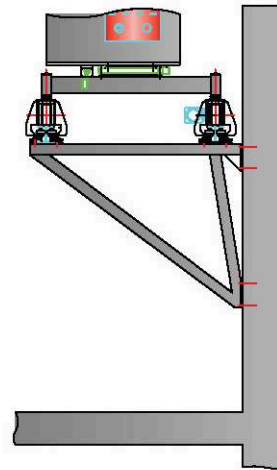

On parapet mounted twin steel track

	CANTILEVER X 1500 MM	CANTILEVER X 2000 MM	CANTILEVER X 3000 MM	CANTILEVER X 4000 MM
A - WIDTH OF CONCRETE RUNWAY	2000	2000	2250	2250
B	200	200	225	225
C - WHEEL GAUGE	1550	1550	1750	1750
D	250	250	275	275
MAXIMUM WHEEL LOAD IN 45° SLEWED POSITION IN " KN"	19.5	23.4	24.4	28.8
TOTAL WEIGHT OF THE SYSTEM WITH CRADLE, SWL & IF IN KN	29.8	33.2	41.0	47.3
SAFE WORKING LOAD (SWL) ON THE CRADLE IN KG	240	240	240	240

Note: The data provided is for general information only & subject to change without prior notice for upgradation & application. Technical data for specific application available on request.

Powered Trolley on Concrete Runway

with machine slewing, luffing & self powered double stirrup cradle

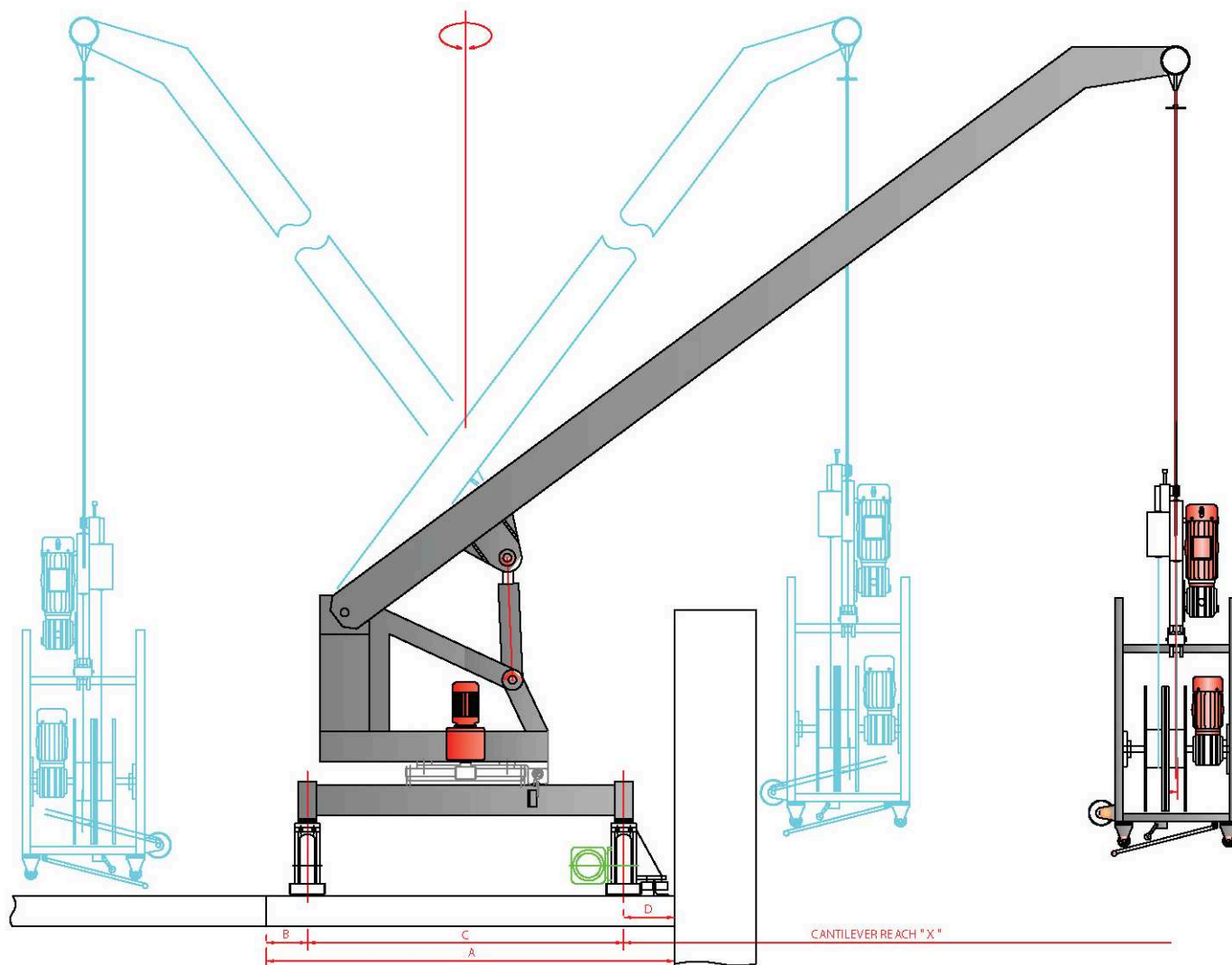

Technical Data

Speeds

Traversing	: 8 M/min
Slewing	: 200° / min
Luffing	: 45° / min
Hoisting	: 8.5 M/min

Motors

Traversing	: 0.25KW x 2nos
Slewing	: 0.37 KW x 1 no
Luffing	: 0.55 KW x 1 no
Hoisting	: 0.75 KW x 2 nos
Wire Winder	: 0.37 KW x 2 nos

Four Wire Suspension system

wire rope Dia	: 8.4 mm
wire rope construction	: 5x26
No of wire ropes	: 4 nos
Finish	: Galvanised
Breaking Load	: 51 KN each

Controls at Cradle

- Cable Control

Finishing & Corrosion Protection

- Abrasive blasting to SA2.5
- 1 coat Zinc Primer
- 2 coats of polyurethane to required RAL colour code

Roof Trolley Track

Track	: RCC Concrete Runway
Trolley Guidance	: Hot dip galvanised steel angular guide rail

Cradle

Basket size	: 2000Lx600Wx1100H
Overall Size	: 2000Lx725Wx1800H
Safe Working Load	: 240 kg or as ordered
Options	: Special sizes available to suit requirement

Cradle Option

- Self Powered Double Stirrup Cradle
- Walk through Stirrup Cradle
- Self Powered Slewing Cadle

Safety Features

- Electromagnetic brake
- Slack rope safety device with brake
- Top limit safety switch
- Bottom limit & obstruction sensing safety switch with trip bar
- Traversing Safety limit - left end
- Traversing Safety limit - right end
- Slewing safety limit switch - CW
- Slewing safety limit switch - CCW
- Luffing safety switch-UP
- Luffing safety switch-DOWM
- ELCB
- No Power Emergency Manual Descent

Power Supply

380/415 V-3Ph-50Hz+Earth&Neutral

Options available with Powered Trolley with machine slewing and Luffing

Track Options

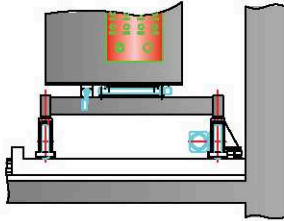

On concrete runway

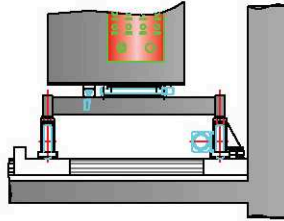

On twin RCC beam runway

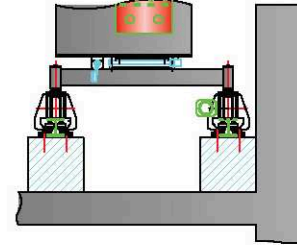

On RCC pedestals
mounted twin steel track

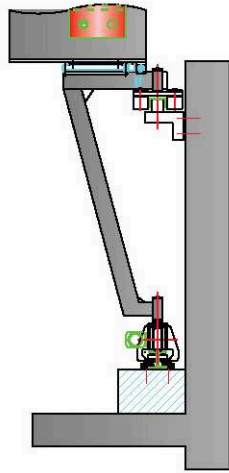

On parapet & pedestal
mounted twin steel track

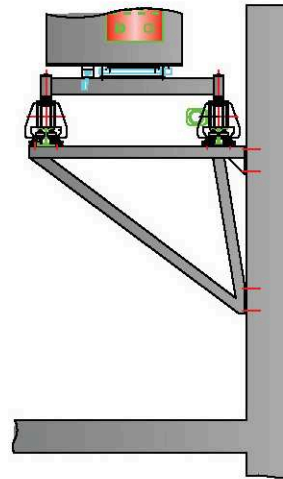

On parapet mounted
twin steel track

	CANTILEVER X 1500 MM	CANTILEVER X 2000 MM	CANTILEVER X 2500 MM	CANTILEVER X 3000 MM
A - WIDTH OF CONCRETE RUNWAY	2000	2000	2250	2250
B	200	200	200	200
C - WHEEL GAUGE	1550	1550	1800	1800
D	250	250	250	250
MAXIMUM WHEEL LOAD 45° SLEWED POSITION IN " KN"	21.5	25.4	26.9	31.2
TOTAL WEIGHT OF THE SYSTEM WITH CRADLE, SWL & IF IN KN	32.7	38.0	41.5	49.8
SAFE WORKING LOAD (SWL) ON THE CRADLE IN KG	200	200	200	200

Note: The data provided is for general information only & subject to change without prior notice for upgradation & application. Technical data for specific application available on request.

Gantry Ladder

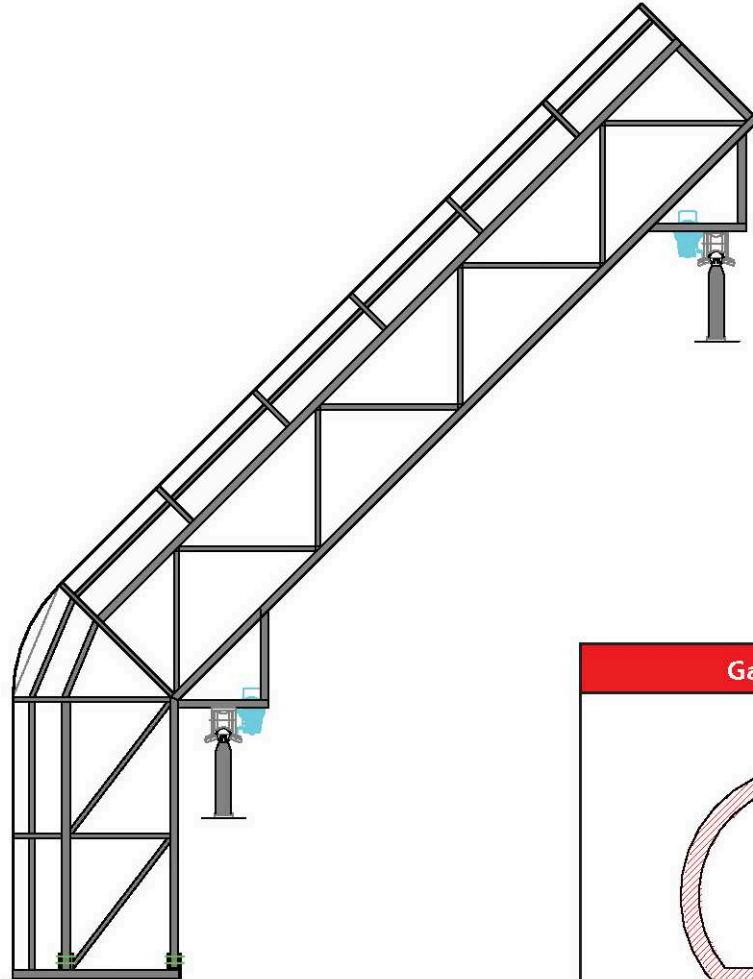
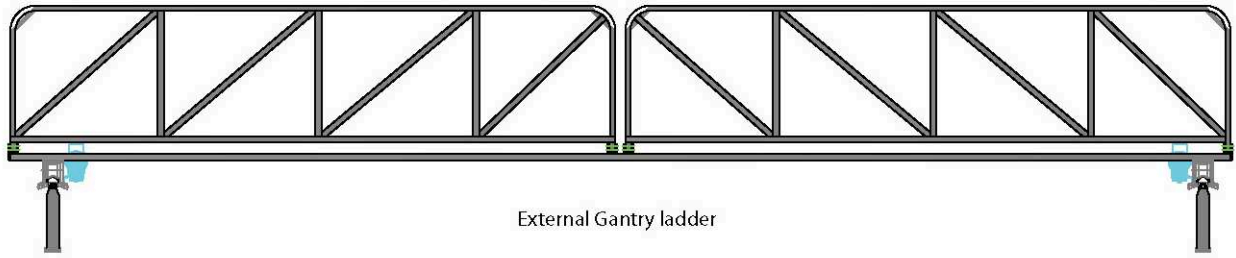

Revolving Gantry ladder

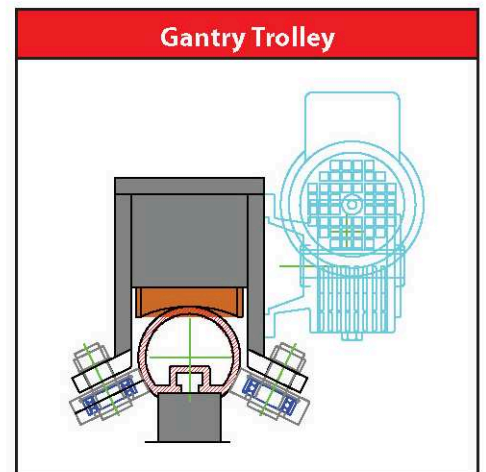
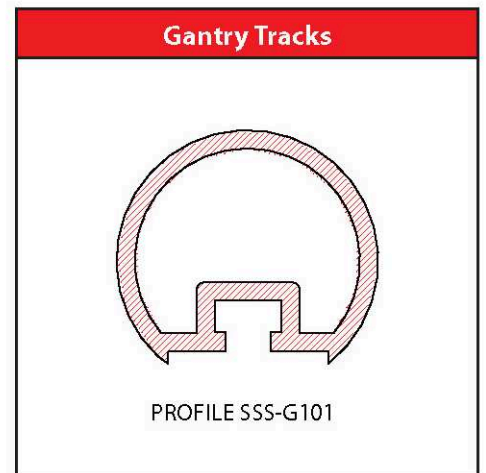

Technical Data

Material : Aluminium Alloy 6061 Temp T6
Weight : 6.323 Kg/M
Length : 6.0 M INDIVIDUAL LENGTHS
Finish : Mill Finish/ Anodized/ Polyurethane
Coat/ Powder Coat to Required Ral Code

Safe Suspended Load : 6 kn per trolley
Traversing Speed : 7 m/min
Traversing Drive : 0.37 kw X 2Nos
Power Supply : 400v/3ph/50hz

Davit Systems

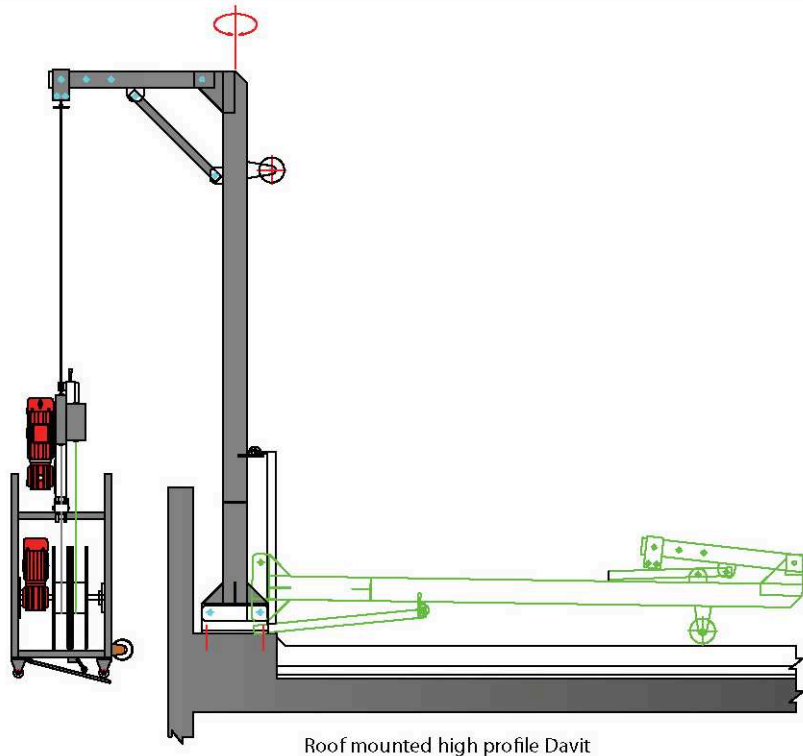

Roof mounted high profile Davit

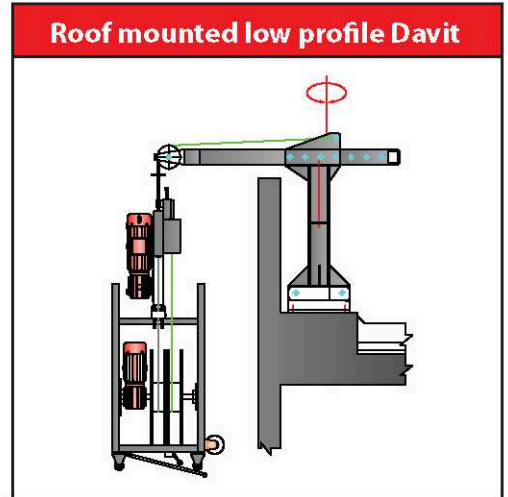

Roof mounted low profile Davit

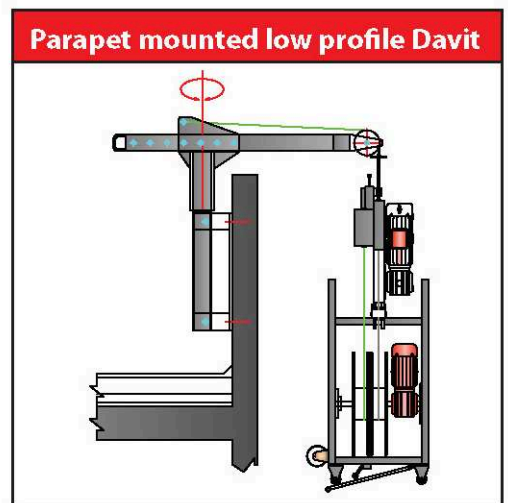

Parapet mounted low profile Davit

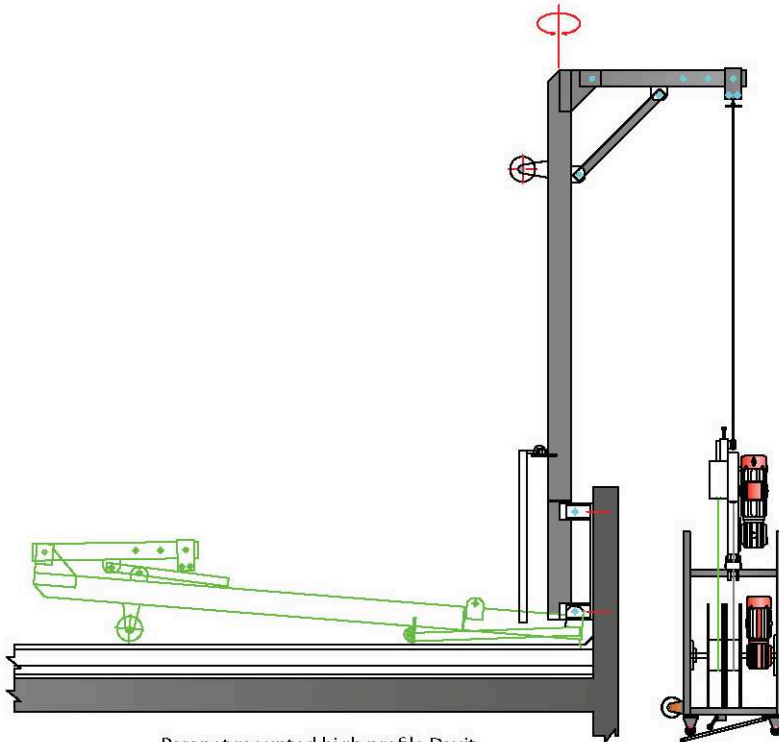

Parapet mounted high profile Davit

Technical Data

SAFE WORKING LOAD	
One man Cradle 1 to 1.5 M	Two man Cradle 2M or more
120 KG (or as ordered)	240 KG (or as ordered)

MOTORS		
	One man Cradle 1 to 1.5 M	Two man Cradle 2M or more
Hoisting	0.75Kw x 1 No	0.75Kw x 2 No
Wire Winder	0.37Kw x 1 No	0.75Kw x 2 No

Speeds
 Slewing : Manual
 Hoisting : 8.5 M/min

Wire Rope Suspension system

Wire rope Dia : 8.4 mm
 Wire rope construction : 5x26
 Finish : Galvanised
 Breaking Load : 51 KN each

NO OF WIRE ROPES	
One man Cradle	Two man Cradle
2	4

Cradle Option

Self Powered Cradle
 Self Powered Slewing Cradle
 Self Powered Walkthrough Cradle

Power Supply

380/415 V-3Ph-50Hz+Earth&Neutral

Safety Features

- Electromagnetic brake
- Slack rope safety device with brake
- Top limit safety switch
- Bottom limit & obstruction sensing safety switch with trip bar
- ELCB
- No Power Emergency Manual Descent
- Emergency Stop

Roof Trolley on steel tracks

with winch on trolley, machine slewing, spreader slewing, telescoping & standard cradle

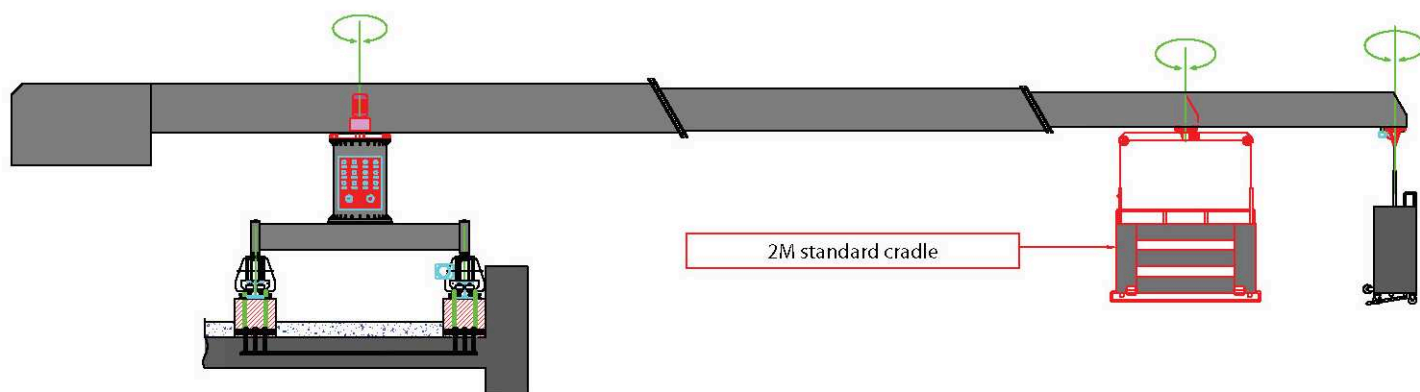

Technical Data

General

Maximum Telescopic Reach : As required
Minimum Telescopic Reach : As required

Standard Cradle

Overall Size : 2000Lx800Wx1800H (mm)
Basket Size : 2000Lx600Wx1100H (mm)
Safe Working Load : 240 kg (or as ordered)

Cradle Options

Standard Cradle
Cantilever Cradle
Pantograph Cradle
Telescopic Cradle

Speeds

Hoisting : 8 to 12 M/min
Slewing : 8 M/min TIP SPEED
Spreader Slewing : 1.6 rpm
Traversing : 8 M/min
Telescoping : 6 M/min

Motors

Hoisting : 2.2 KW x 1 no (or as required)
Slewing : As required
Spreader Slewing : 0.25 KW x 1 no
Traversing : As required
Telescoping : As required

Four Wire Suspension system

wire rope Dia : 7 mm (with conductor core)
wire rope construction : 6x19
No of wire ropes : 4 nos
Finish : Galvanised
Breaking Load : 3509 kg each
Wire Rope Option : 7mm or 8mm with or without
Conductor Core

Controls in Cradle Control Panel

- Hoisting Up & Down
- Mains On Indication
- Key Switch
- Emergency Stop

Controls in Roof Machine Control Panel

- Hoisting Up & Down
- Slewing CW & CCW
- Spreader Slewing CW & CCW
- Traversing Left & Right
- Telescoping In & Out
- Mains On Indication
- Key Switch
- Emergency Stop

Controls in Jib Head Control Panel

- Slewing CW & CCW
- Spreader Slewing CW & CCW
- Traversing Left & Right
- Telescoping In & Out

Power Supply

32Amps-380/415 V-3Ph-50Hz+Earth&Neutral

Safety Features

- Electromagnetic brake
- Overspeed Block Stop with brake
- Cradle overload
- Top limit safety switch
- Bottom limit & obstruction sensing safety switch
- Slewing safety limit switches - CW & CCW
- Slewing limit mechanical end stop
- Spreader Slewing safety switches-CW & CCW
- Spreader Slewing limit mechanical end stop
- Telescoping In & Out safety limit switches
- Telescoping limit mechanical end stop
- Traversing left & right limit switches & block stop
- Inverter Controlled soft start & stop to minimise impact loading on machine & civil structure
- Earth Leakage Circuit Breaker (ELCB)
- No Power Emergency Manual Descent
- Emergency Stop

NOTES

1. MATERIALS:

- All structural members are steel grade 43
- Slewing fasteners Galvanised 10.9 grade
- Other fasteners Galvanised 8.8 grade

2. CIVIL STRUCTURE DESIGN

- Civil structure design for roof and pedestals by others to withstand the loads provided.

3. STRUCTURAL ANALYSIS & CHECKING CODES

- EN1808(1999) Safety requirements of window cleaning equipment
- CP3:Chapter5, Part2 (Basic data for design of buildings - Wind Loads)
- BS5950:2000 (Structural use of steelwork in buildings)

4. FINISH

- Abrasive blast to SA2.5 and painted with Sigma Paints' Sigmadur 3 coat system to required RAL colour code to be provided by client.

Options available with Roof Trolley

with winch on trolley, machine slewing and Spreader slewing

Optional luffing

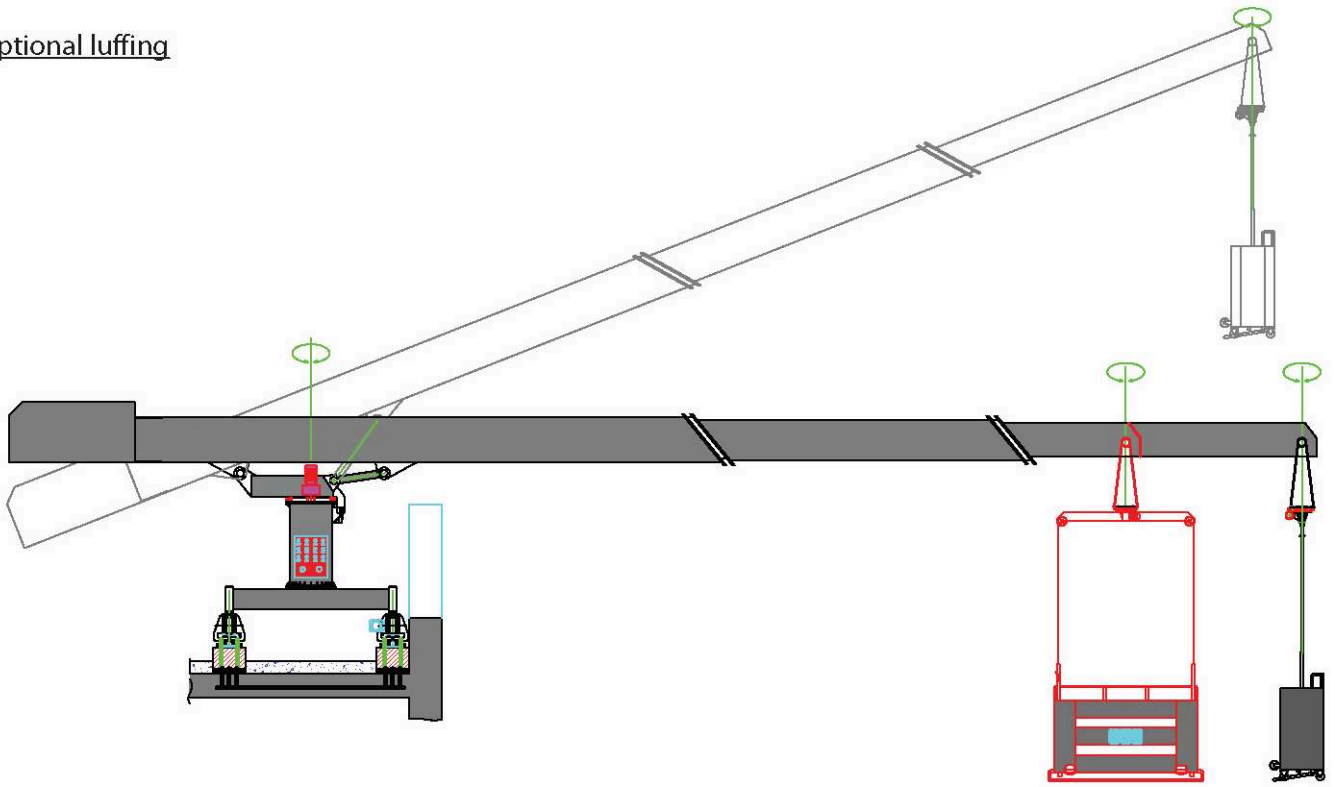

Track & Fixed system options

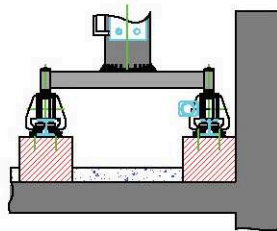

On RCC pedestals
mounted twin steel track

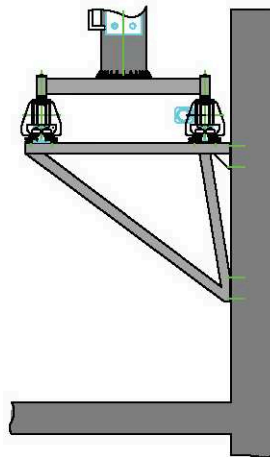

On parapet mounted
twin steel track

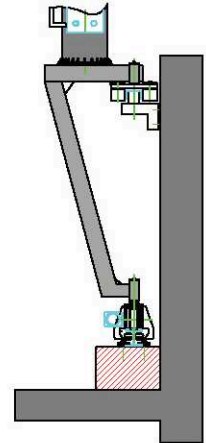

On parapet & pedestal
mounted twin steel track

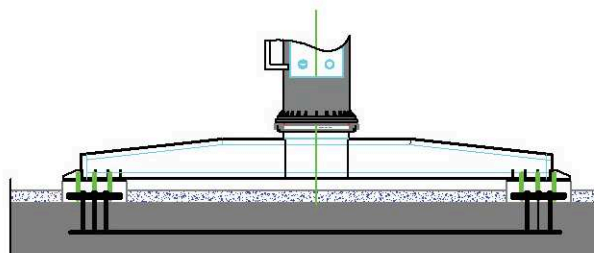

Fixed system

FURTHER OPTIONS

- Telescopic trollies with luffing

Note: The data provided is for general information only & subject to change without prior notice for upgradation & application. Technical data for specific application available on request.

Roof Trolley on steel tracks

with winch on trolley, machine slewing, spreader slewing, knuckle jib & standard cradle

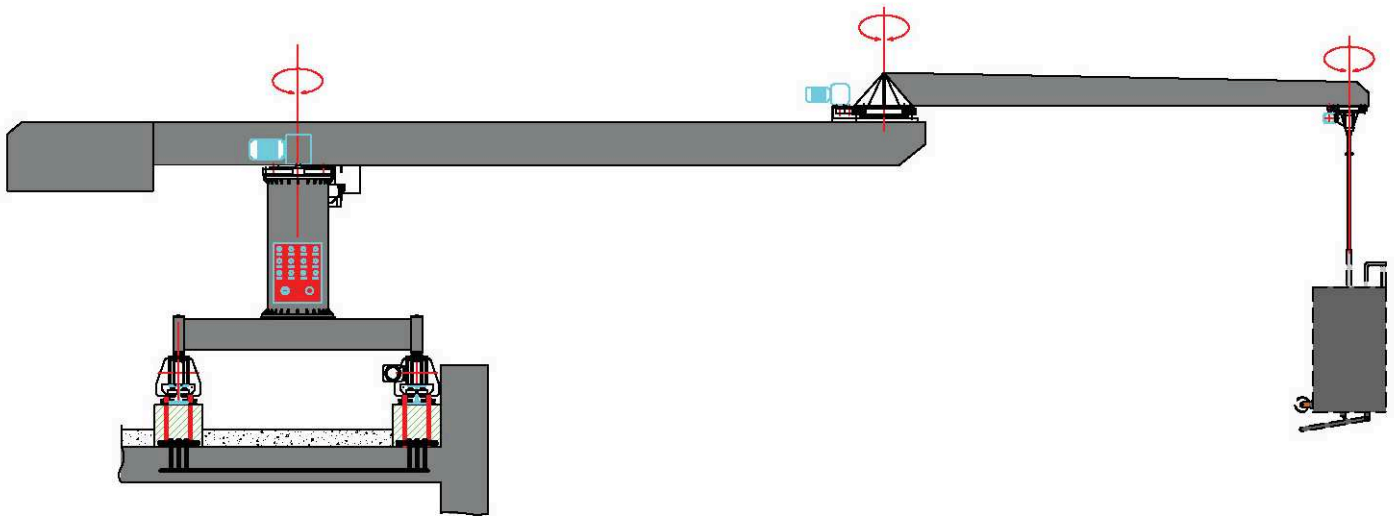

Technical Data

Standard Cradle

Overall Size	: 2000Lx800Wx1800H (mm)
Basket Size	: 2000Lx600Wx1100H (mm)
Safe Working Load	: 240 kg (or as ordered)

Cradle Options

Standard Cradle
Cantilever Cradle
Pantograph Cradle
Telescopic Cradle

Speeds

Hoisting	: 8 TO 12 M/min
Slewing	: 8 M/min TIP SPEED
Spreader Slewing	: 8 M/min TIP SPEED
Knuckle Jib Slewing	: 8 M/min TIP SPEED
Traversing	: 8 M/min

Motors

Hoisting	: As required
Slewing	: As required
Knuckle Jib Slewing	: As required
Spreader Slewing	: As required
Traversing	: As required

Four Wire Suspension system

wire rope Dia	: 7 mm (with conductor core)
wire rope construction	: 6x19
No of wire ropes	: 4 nos
Finish	: Galvanised
Breaking Load	: 3509 kg each
Wire Rope Options	: 7mm or 8mm with or without Conductor Core

Power Supply

32Amps-380/415V-3Ph-50Hz+ Earth&Neutral

Safety Features

- Electromagnetic brake
- Overspeed Block Stop with brake
- Overload
- Top limit safety switch
- Bottom limit & obstruction sensing safety switch
- Slewing safety limit switches - CW
- Slewing safety limit switches - CCW
- Spreader Slewing safety switches-CW
- Spreader Slewing safety switches-CCW
- Traversing left & right limit switches & block stop
- Inverter Controlled soft start & stop to minimize impact loading on machine & civil structure
- Knuckle Jib Slewing Safety Switch - CW
- Knuckle Jib Slewing Safety Switch - CCW
- Earth Leakage Circuit Breaker (ELCB)
- No Power Emergency Manual Descent
- Emergency Stop

NOTES

1. MATERIALS:

- All structural members are steel grade 43
- Slewing fasteners Galvanised 10.9 grade
- Other fasteners Galvanised 8.8 grade

2. CIVIL STRUCTURE DESIGN

- Civil structure design for roof and pedestals by others to withstand the loads provided.

3. STRUCTURAL ANALYSIS & CHECKING CODES

- EN1808(1999) Safety requirements of window cleaning equipment
- CP3:Chapter5, Part2 (Basic data for design of buildings - Wind Loads)
- BS5950:2000 (Structural use of steelwork in buildings)

4. FINISH

- Abrasive blast to SA2.5 and painted with Sigma Paints' Sigmadur 3 coat system to required RAL colour code to be provided by client.

Roof Trolley on steel tracks

with winch on trolley, machine slewing, spreader slewing, knuckle jib & standard cradle

Optional system

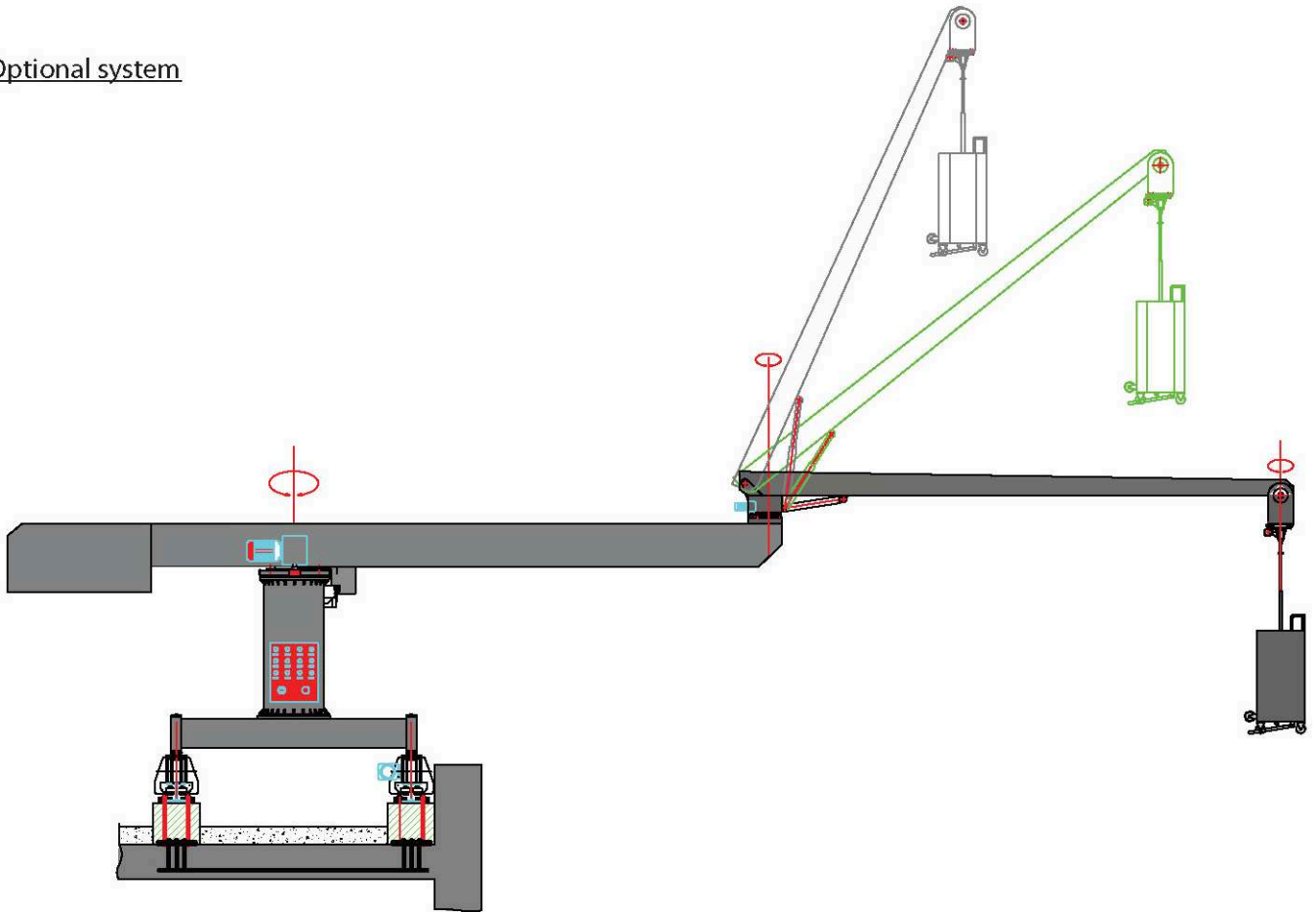

Track & Fixed system options

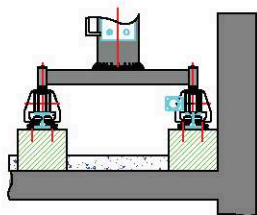

On RCC pedestals mounted twin steel track

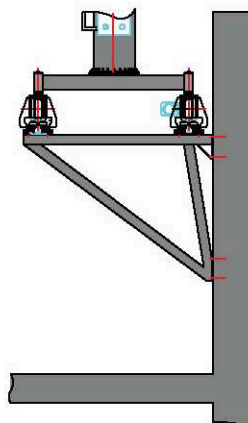

On parapet mounted twin steel track

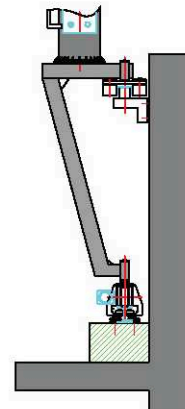

On parapet & pedestal mounted twin steel track

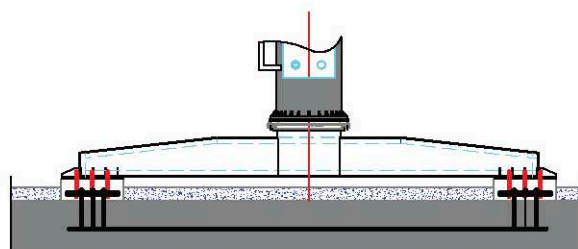

Fixed system

Restraint Systems

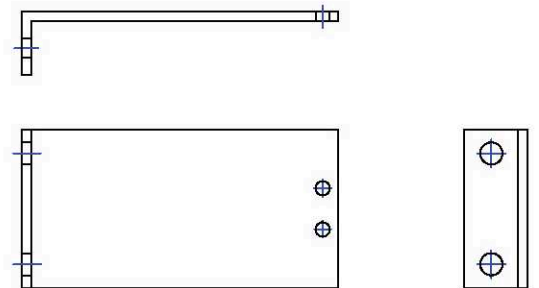
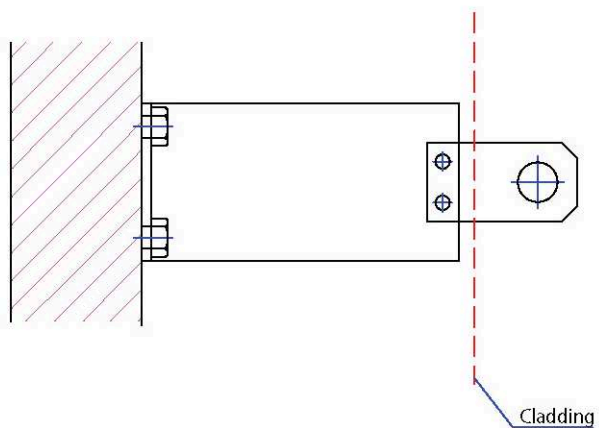
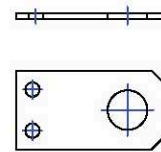
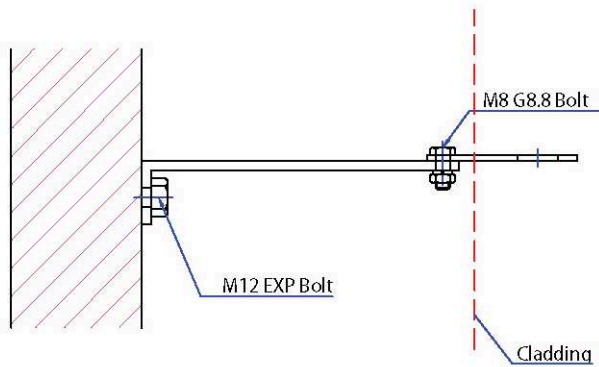
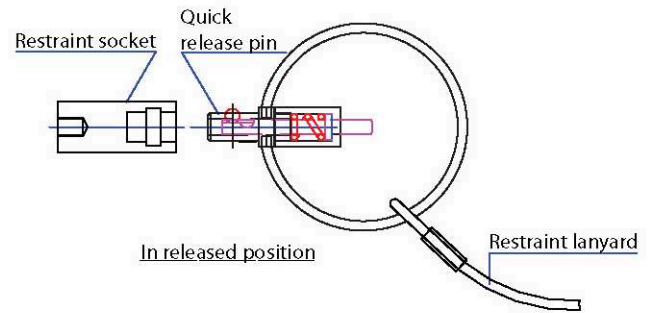
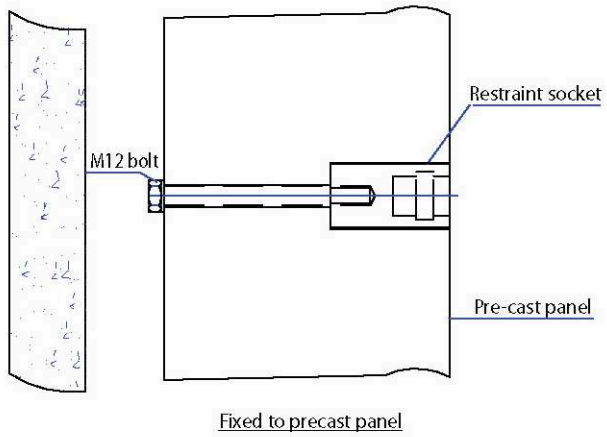
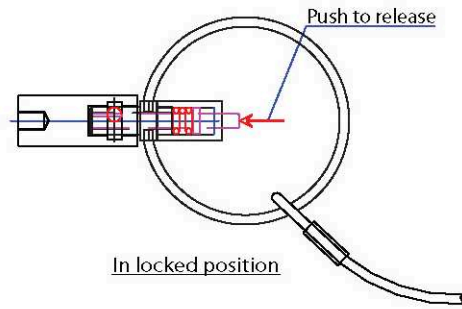
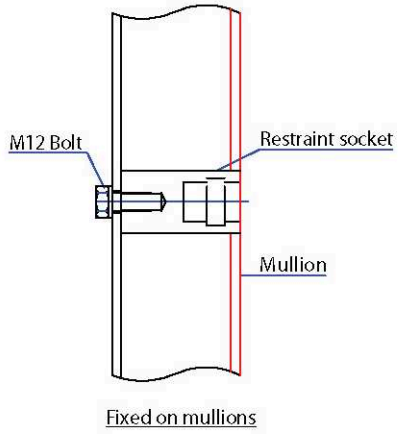

Restraint Systems

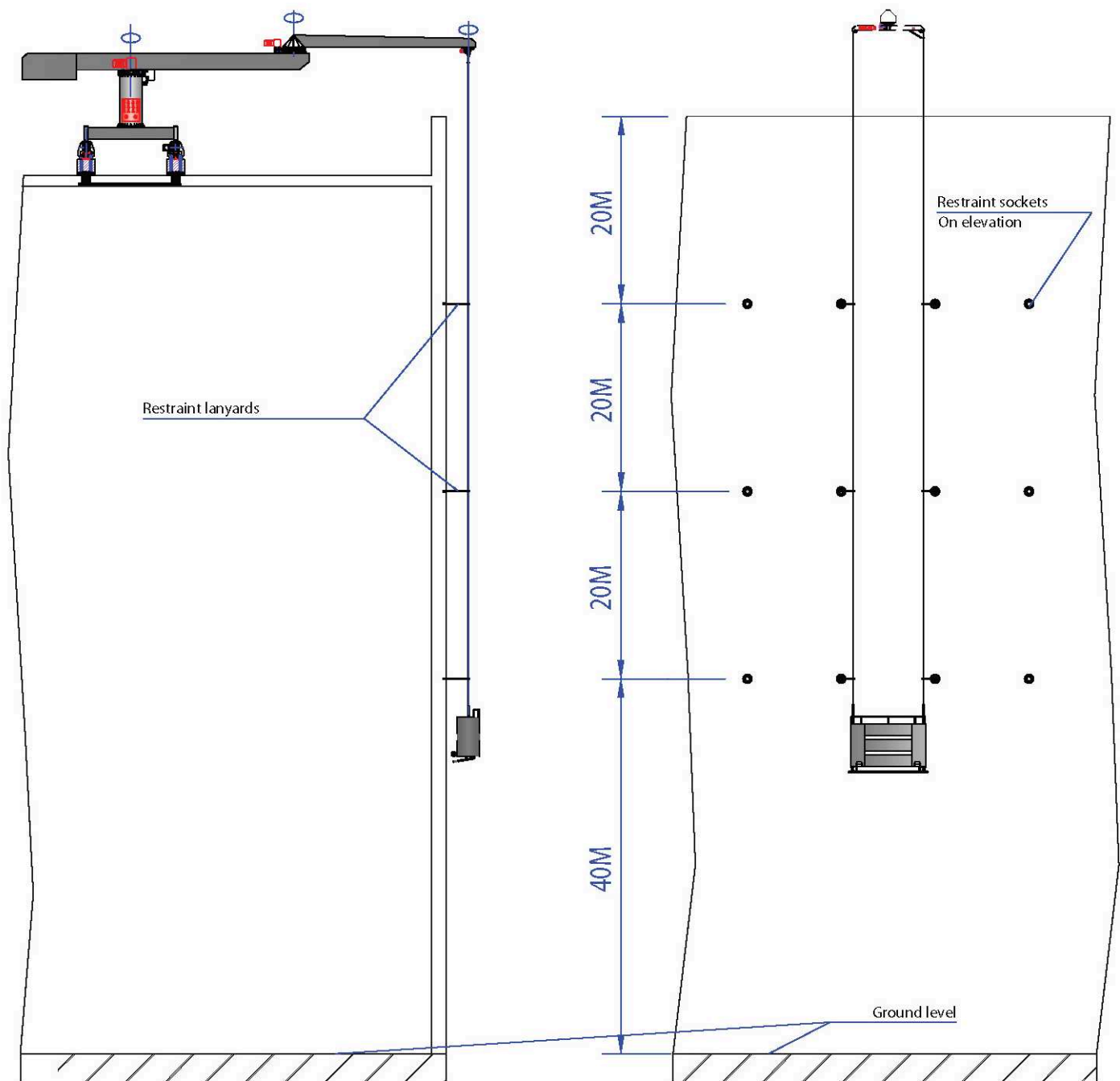

Technical Data

Material - SS316
Load on inserts - 1kN
Horizontal spacing - every 2.5m (or to suit cradle length)
Vertical spacing - every 20m above 40m from ground

Cradles

Self powered cradles

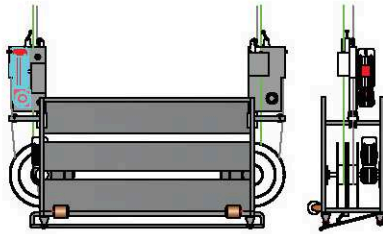

Self powered double stirrup cradle

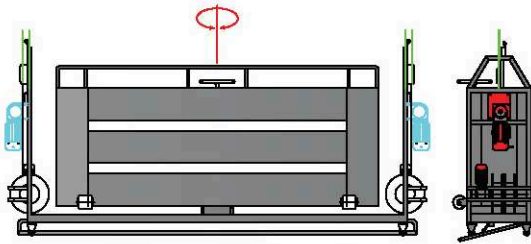

Self powered slewing cradle

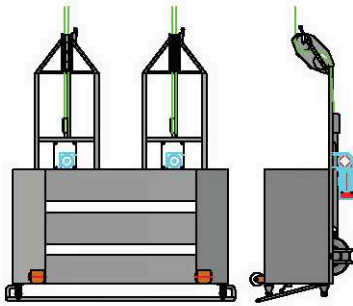

Self powered walkthrough stirrup cradle

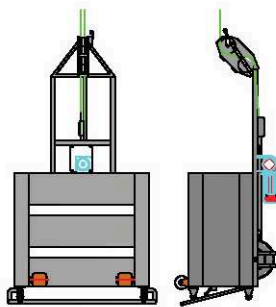

Self powered single stirrup cradle

Cradle technical data

MOTORS		
	Single Stirrup	Double Stirrup
Hoist Motors	0.75 KW X 1 nos.	0.75 KW X 2 nos.
Wire Winder Motors	0.37 KW X 1 nos.	0.37 KW X 2 nos.

Suspension Wire Ropes

Dia of wire rope : 8.4 mm
Construction : 5/26
Finish : Galvanised
Breaking Load : 51 KN

SAFE WORKING LOAD	
One man Cradle 1 to 1.5 M 120 KG (or as ordered)	Two man Cradle 2M or more 240 KG (or as ordered)

Control Options

- Cable Control

Speeds

Hoisting : 8 to 8.5 m/min

Safety Features

- Electromagnetic Brake
- Slack Rope Safety Device with Brake
- Top Limit Safety Switch
- Bottom Limit & Obstruction Sensing Safety Switch
- No Power Emergency Manual Descent
- Emergency Stop

Cradles for the winch on the roof system

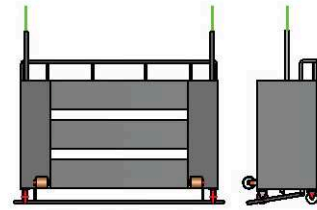

Standard cradle

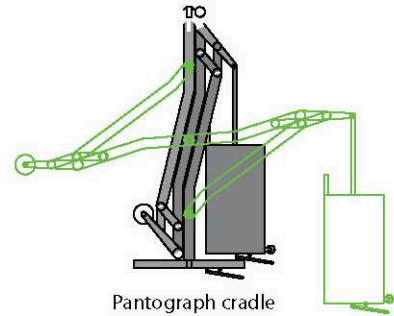

Pantograph cradle

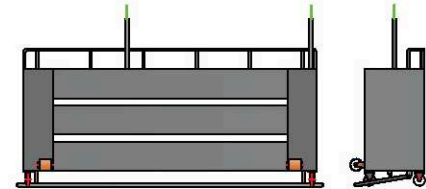

Cantilever cradle

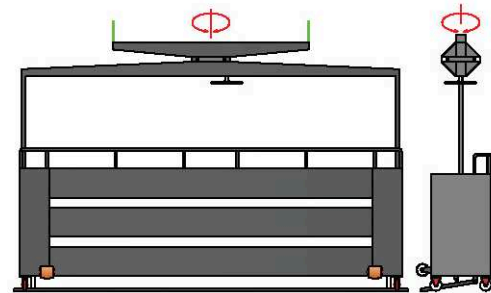

Slewing cradle

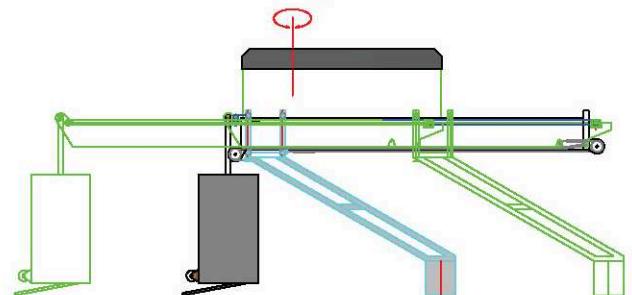

Telescopic cradle

Cradle technical data

Weights & Loads

Total Suspended Load with Cradle,
Wire ropes & Impact Factor : 7.25 KN

SAFE WORKING LOAD	
One man Cradle 1 to 1.5 M 120 KG (or as ordered)	Two man Cradle 2M or more 240 KG (or as ordered)

Suspension Wire Ropes

Dia of wire rope : 7 mm
Construction : 5/26
Finish : Galvanised
Breaking Load : 29 KN
Wire Rope Options : 7 or 8mm with or
without conductor core

Speeds

Hoisting : 8 to 8.5 m/min

Control Options

- Cable Control
- Conductor Wire Rope
- Radio Remote Control

Safety Features

- Electromagnetic Brake
- Slack Rope Safety Device with Brake
- Top Limit Safety Switch
- Bottom Limit & Obstruction Sensing Safety Switch
- No Power Emergency Manual Descent
- Emergency Stop